



ACTUATORS

PNEUMATIC

ELECTRIC

HYDRAULIC

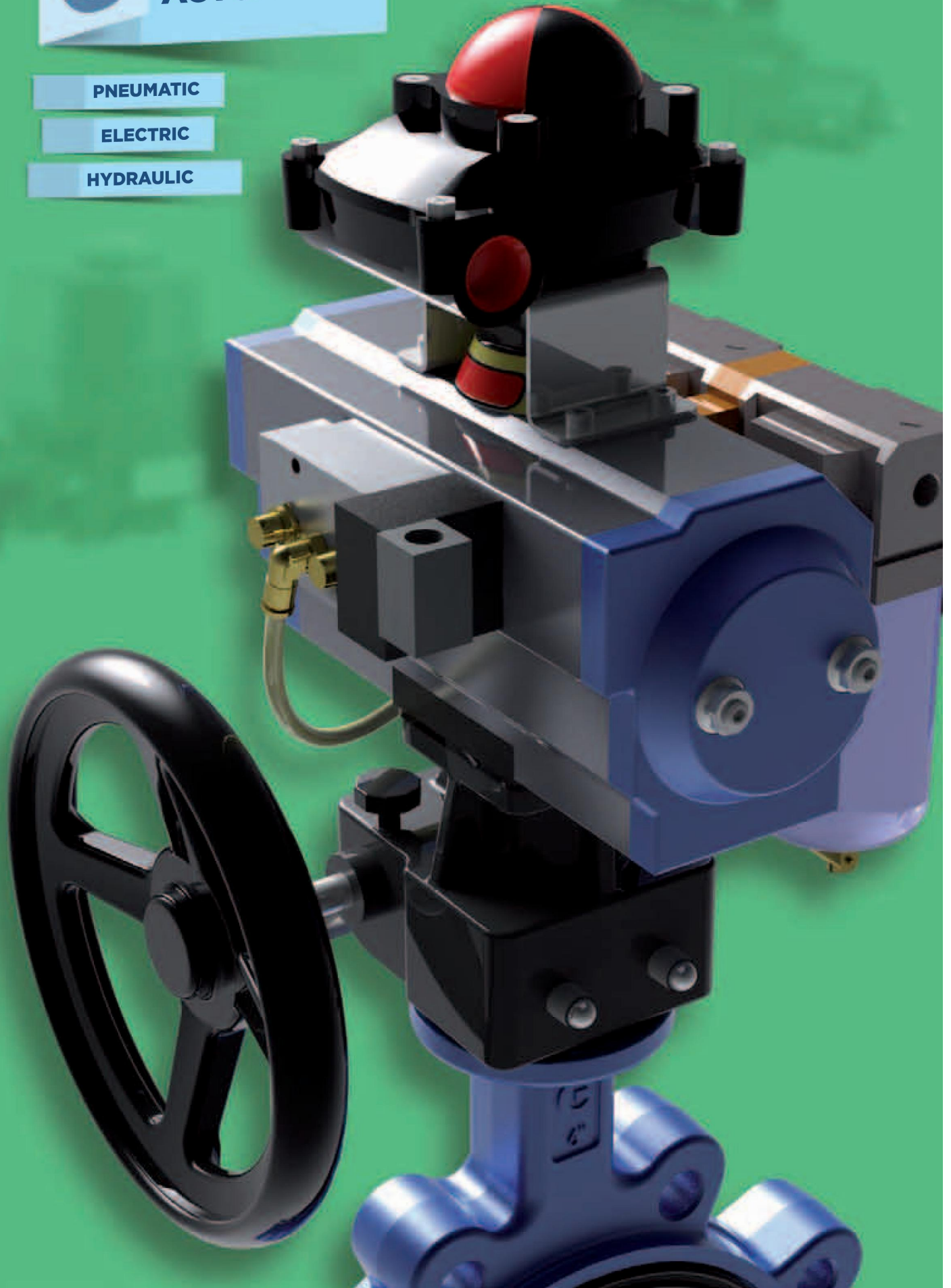

Actuators

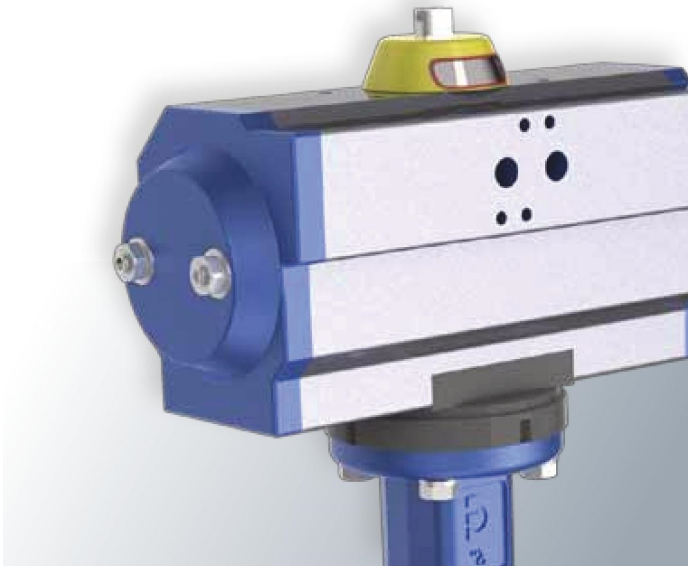

PNEUMATIC ACTUATORS

Technical features	1
Elements list	2
Tables	3
• torque	3
• dimensions	5
Solenoids	6
• options and regulation	6
Positioner	7
Coupling	8
• soft seated valves	8
• PTFE seated valves	10
• Double eccentric valves	10
• valves for hot air and smokes	11
Declutchable gearboxes	12
• aluminium body	12
• cast iron body	13



ELECTRIC ACTUATORS

Actuators J+J	14
• technical features	14
• digital positioner	15
• coupling	15
Actuators Bernard	16
• technical features	16
• electrical features tables	17
• dimensions tables	18
OA Series	18
AS Series 18÷80	19
AS Series 100÷1000	20
• coupling	21
Actuators NA	22
• technical features	22
• dimensions tables	23
• coupling	23

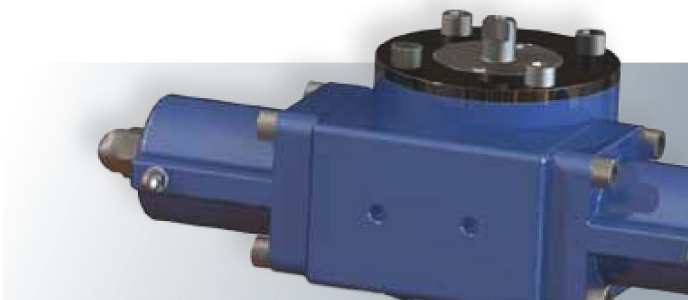

HYDRAULIC ACTUATORS

Hydraulic ARES	24
• technical features	24
• torque tables	25
• elements list	26
• dimensions tables	27
• coupling	28

Pneumatic Actuators

DA double acting - SR spring return

Features:

Max air pressure: **10 bar**
 Temperature: **-20°C / +80°C**
on request: **-50°C / +150°C**
 torque at 5.6 Bar: **31 Nm / 3564 Nm**
 Double travel stop open/close: **±10°**

UT series actuators feature a bi-directional travel stop. Side located stops allow a ±10° adjustment in both closing and opening directions, so guarantee a range of adjustment between 70° and 110° of actuator stroke. Stops can be modified on request to allow higher closing/opening angles

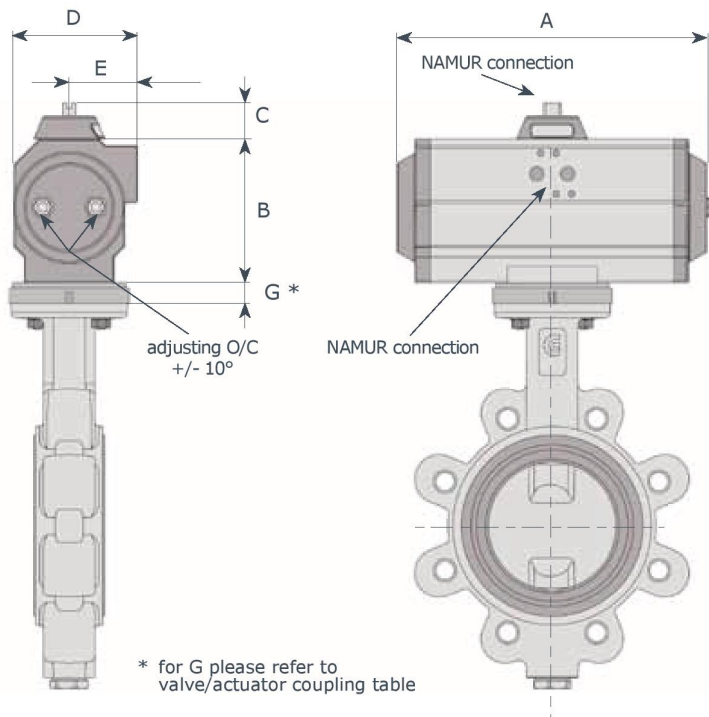
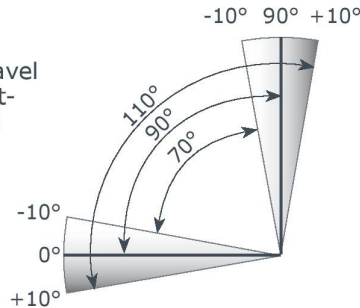

* for G please refer to valve/actuator coupling table

Mod. UT: double acting
 Mod. UTS: single acting spring return

Operating media:

dry/clear air : P max 10 Bar

Temperature:

O-Rings NBR -20° C/+100° C

O-Rings FKM -15° C/+150° C

O-Rings Silicon -50° C/+ 80° C

Rotation: 90°

Regulation range: +/- 10°

Lubrication For Life

Flange:

ISO 5211/DIN 3337

connection for solenoid valve, switches box:

NAMUR VDI / VDE 3845

DA	SR	A	B	C	D	E	DA	SR	A	B	C	D	E
UT 10	UTS 10	119	70	20	67	27	UT 45	UTS 45	351	168.5	30	145	73
UT 15	UTS 15	165	81	30	81	47	UT 50	UTS 50	361	202	30	181	91
UT 17	UTS 17	197	81	30	81	47	UT 55	UTS 55	418	202	30	181	91
UT 20	UTS 20	177	98	30	96	54	UT 60	UTS 60	444	274	30	232	116
UT 25	UTS 25	239	98	30	96	54	UT 65	UTS 65	502	274	30	232	116
UT 30	UTS 30	230	117	30	114	62	UT 70	UTS 70	587	332	30	332	166
UT 35	UTS 35	246	154	30	131	65.5	UT 75	UTS 75	677	332	30	332	166
UT 40	UTS 40	290	154	30	131	65.5							

* UTS / UTS4 : same dimensions

Pneumatic actuators rack & pinion - UT series

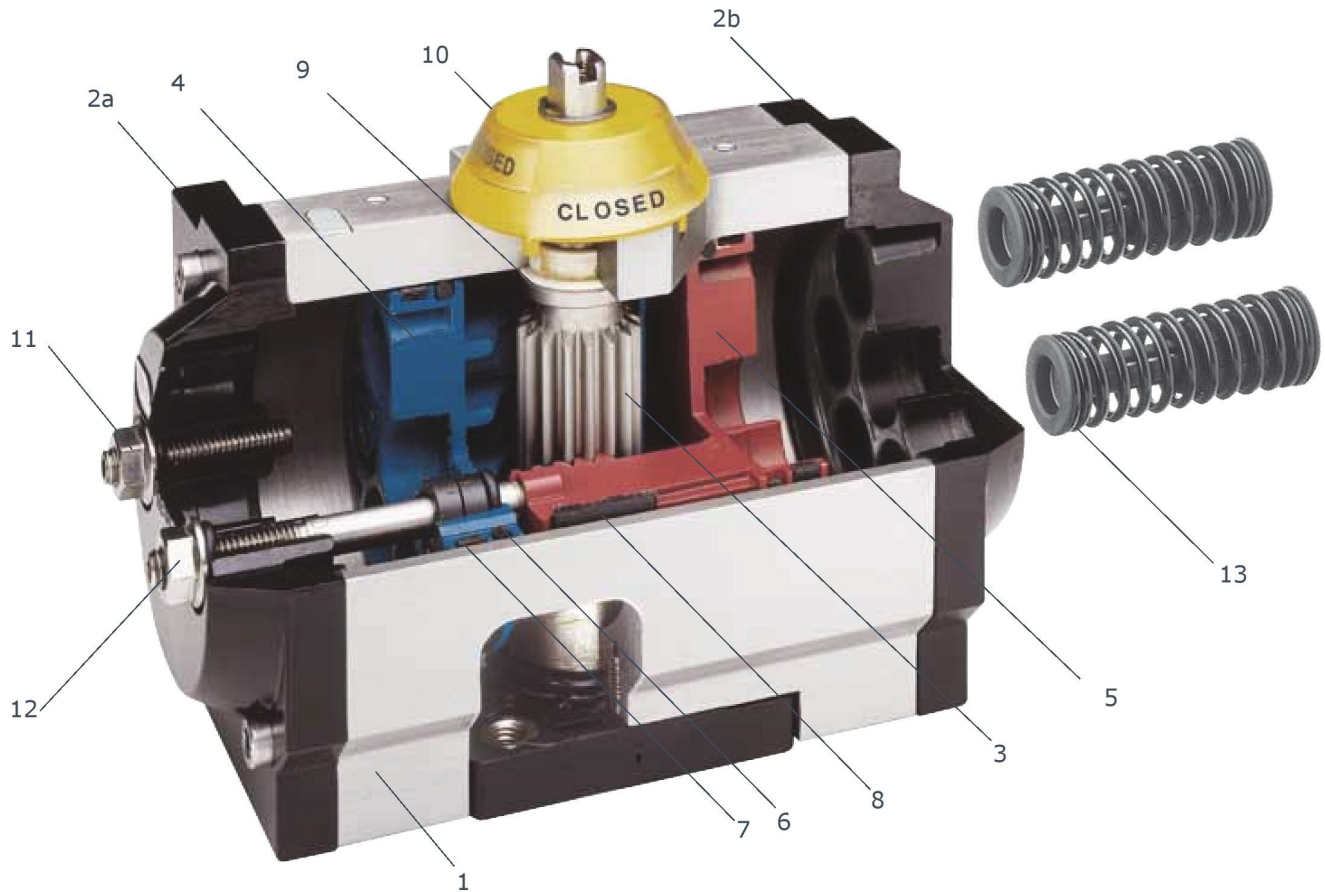

item.	part	material
1	body	<ul style="list-style-type: none"> • anodized aluminium ASTM B210
2a	left end cap	<ul style="list-style-type: none"> • die-cast aluminium UNI 5076
2b	right end cap	<ul style="list-style-type: none"> • die-cast aluminium UNI 5076
3	pinion	<ul style="list-style-type: none"> • steel SAE 11L14 • nickel coated steel acc. to ASTM B733
4	left piston	<ul style="list-style-type: none"> • die-cast aluminium UNI 5076
5	right piston	<ul style="list-style-type: none"> • die-cast aluminium UNI 5076
6	piston O-ring	<ul style="list-style-type: none"> • NBR
7	bearing pad	<ul style="list-style-type: none"> • techno-polymer
8	piston skate	<ul style="list-style-type: none"> • techno-polymer
9	bearing pad upper pinion	<ul style="list-style-type: none"> • techno-polymer
10	position indicator	<ul style="list-style-type: none"> • techno-polymer
11	open travel stop	<ul style="list-style-type: none"> • stainless steel AISI 304
12	close travel stop	<ul style="list-style-type: none"> • stainless steel AISI 304
13	spring SR mod.	<ul style="list-style-type: none"> • spring steel

Options body and end cap: hard anodizing or PTFE coating or epoxy powder coated units or electroless nickel plating.

Torque chart - double acting - Nm

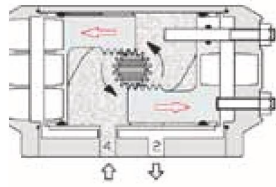

4: inlet air / 2: outlet air

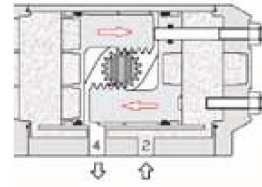

2: inlet air / 4: outlet air

TIPO/TYPE	2 Bar	3 Bar	4 Bar	5 Bar	5,62 Bar	6 Bar	7 Bar	8 Bar	9 Bar	10 Bar
UT 10	2.52	5.0	10.1	12.6	14.1	15.1	17.6	10.5	--	--
UT 15	11	17	22	28	31	33	39	44	50	55
UT 17	15	22	29	36	41	44	51	58	65	73
UT 20	20	30	40	50	57	60	70	80	90	100
UT 25	30	45	60	76	85	91	106	121	136	151
UT 30	40	60	80	101	113	121	141	161	181	201
UT 35	64	97	129	161	180	193	226	258	290	322
UT 40	81	121	161	202	226	242	282	323	363	403
UT 45	126	189	252	315	353	377	440	503	566	629
UT 50	181	272	362	453	509	544	634	725	815	906
UT 55	242	362	483	604	676	725	846	966	1087	1208
UT 60	366	550	733	916	1030	1099	1282	1466	1649	1832
UT 65	483	725	966	1208	1358	1450	1691	1933	2174	2416
UT 70	946	1419	1892	2365	2658	2838	3311	3784	--	--
UT 75	1268	1903	2537	3171	3564	3805	4439	5074	--	--

Torque chart - single acting 90° - Nm

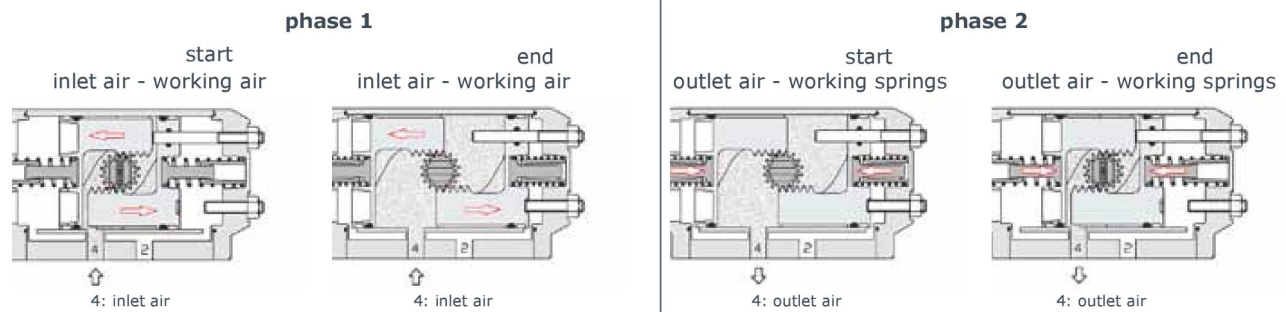

type	springs	phase 1														phase 2	
		3 bar		4 bar		5 bar		5.6 bar		6 bar		7 bar		8 Bar		start	end
		start	end	start	end	start	end	start	end	start	end	start	end	start	end		
UT 10	1+1	5,1	3,9	7,6	6,4	10,1	8,9	11,6	10,4	12,6	11,4	15,1	13,9	17,7	13,9	3,7	2,5
	2+2	2,6	0,2	5,1	2,7	7,6	5,2	9,1	6,7	10,1	7,7	12,6	10,2	15,2	10,2	7,4	5,0
	3+3	--	--	--	--	5,1	1,5	6,6	3,0	7,6	4,0	10,1	6,5	12,7	6,5	11,2	7,5
UT 15	2+2	10,5	8,1	16,0	13,6	21,5	19,1	24,6	22,5	27	24,6	32,5	30,1	38	35,6	8,4	6,0
	3+3	7,4	3,9	12,9	9,4	18,4	14,9	21,8	18,3	23,9	20,4	29,4	25,9	34,9	31,4	12,6	9,1
	4+4	--	--	9,9	5,1	15,4	10,6	18,8	14	20,9	16,1	26,4	21,6	31,9	27,1	16,9	12,1
	5+5	--	--	6,9	0,9	12,4	6,4	15,8	9,8	17,9	11,9	23,4	17,4	28,9	22,9	21,1	15,1
UT 17	2+2	14,5	11,2	21,8	18,5	29,0	25,7	33,4	30,1	36,3	33	43,5	40,2	50,8	47,5	10,5	7,2
	3+3	10,9	6,0	18,2	13,3	25,4	20,5	29,8	24,9	32,7	27,8	39,9	35	47,2	42,3	15,7	10,8
	4+4	7,3	0,8	14,6	8,1	21,8	15,3	26,2	19,7	29,1	22,6	36,3	29,8	43,6	37,1	20,9	14,4
	5+5	--	--	10,9	2,9	18,1	10,1	22,5	14,5	25,4	17,4	32,6	24,6	39,9	31,9	26,1	18,1
UT 20	2+2	19,6	16,2	29,6	26,2	39,6	36,2	46,1	42,7	49,6	46,2	59,6	56,2	69,6	66,2	13,8	10,4
	3+3	14,4	9,2	24,4	19,2	34,4	29,2	40,9	35,7	44,4	39,2	54,4	49,2	64,4	59,2	20,8	15,6
	4+4	9,2	2,3	19,2	12,3	29,2	22,3	35,7	28,8	39,2	32,3	49,2	42,3	59,2	52,3	27,7	20,8
	5+5	--	--	14,0	5,4	24,0	15,4	30,5	21,9	34	25,4	44	35,4	54	45,4	34,6	26,0
	7+5	--	--	--	--	18,8	8,4	25,3	14,9	28,8	18,4	38,8	28,4	48,8	38,4	41,6	31,2

Torque chart - single acting 90° - Nm

type	springs	phase 1														phase 2	
		3 bar		4 bar		5 bar		5.2 bar		6 bar		7 bar		8 Bar		start	end
		start	end	start	end	start	end	start	end	start	end	start	end	start	end		
UT 25	2+2	31,3	23,2	46,4	38,3	61,5	53,4	70,5	62,4	76,6	68,5	91,7	83,6	106,8	98,7	22,1	14,0
	3+3	24,4	12,1	39,5	27,2	54,6	42,3	63,6	51,3	69,7	57,4	84,8	72,5	99,9	87,6	33,2	20,9
	4+4	17,4	1,1	32,5	16,2	47,6	31,3	56,6	40,3	62,7	46,4	77,8	61,5	92,9	76,6	44,2	27,9
	5+5	--	--	25,5	5,1	40,6	20,2	49,6	29,2	55,7	35,3	70,8	50,4	85,9	65,5	55,3	34,9
	7+5	--	--	--	--	33,6	9,2	42,6	18,2	48,7	24,3	63,8	39,4	78,9	54,5	66,3	41,9
UT 30	2+2	39,2	32,0	59,3	52,1	79,4	72,2	91,6	84,4	99,5	92,3	119,6	112,4	139,7	132,5	28,3	21,1
	3+3	28,7	17,9	48,8	38,0	68,9	58,1	81,4	70,3	89	78,2	109,1	98,3	129,2	118,4	42,4	31,6
	4+4	18,1	3,7	38,2	23,8	58,3	43,9	70,5	56,1	78,4	64	98,5	84,1	118,6	104,2	56,6	42,2
	5+5	--	--	27,7	9,7	47,8	29,8	60	42	67,9	49,9	88	70	108,1	90,1	70,7	52,7
	7+5	--	--	--	--	37,3	15,6	49,5	27,8	54,7	35,7	77,5	55,8	97,6	75,9	84,9	63,2
UT 35	2+2	62,0	50,1	94,2	82,3	126,5	114,6	145,8	133,9	158,7	146,8	190,9	179	223,1	211,2	46,5	34,6
	3+3	44,6	26,9	76,8	59,1	109,1	91,4	128,4	110,7	141,3	123,6	173,5	155,8	205,7	188	69,7	52,0
	4+4	27,2	3,6	59,5	35,8	91,8	68,1	111,1	87,4	124	100,3	156,2	132,5	188,4	164,7	93,0	69,3
	5+5	--	--	42,2	12,6	74,5	44,9	93,8	64,2	106,7	77,1	138,9	109,3	171,1	141,4	116,2	86,6
	7+5	--	--	--	--	57,1	21,6	76,4	40,9	89,3	53,8	121,5	86	153,7	118,2	139,5	104,0
UT 40	2+2	79,0	63,9	119,3	104,2	159,6	144,5	183,8	168,7	199,9	184,8	240,3	225,2	280,6	265,5	57,0	41,9
	3+3	58,1	35,4	98,4	75,7	138,7	116	162,9	140,2	179	156,3	219,4	196,7	259,7	237	85,5	62,8
	4+4	37,2	6,8	77,5	47,1	117,8	87,4	142	111,6	158,1	127,7	198,5	168,1	238,8	208,4	114,1	83,7
	5+5	--	--	56,5	18,6	96,8	58,9	121	83,1	137,1	99,2	177,5	139,6	217,8	179,9	142,6	104,7
	7+5	--	--	--	--	75,9	30,4	100,1	54,6	116,2	70,7	156,6	111,1	196,9	151,4	171,1	125,6
UT 45	2+2	125,6	88,3	188,5	151,2	251,4	214,1	289,6	252,3	314,3	277	377,2	339,9	440,1	402,8	100,4	63,1
	3+3	94,0	38,1	156,9	101,0	219,8	163,9	258	202,1	282,7	226,8	345,6	289,7	408,5	352,6	150,6	94,7
	4+4	--	--	125,4	50,8	188,3	113,7	226,5	151,9	251,2	176,6	314,1	239,5	377	302,4	200,8	126,2
	5+5	--	--	--	--	156,7	63,5	194,9	101,7	219,6	126,4	282,5	189,3	345,4	252,2	251,0	157,8
	7+5	--	--	--	--	125,2	13,3	163,4	51,5	188,1	76,2	251	139,1	313,9	202	301,2	189,3
UT 50	2+2	173,7	147,5	264,3	238,1	354,9	328,7	411,1	384,9	445,5	419,3	536,1	509,9	626,7	600,5	124,3	98,1
	3+3	124,6	85,3	215,2	175,9	305,8	266,5	362	322,7	396,4	357,1	487	447,7	577,6	538,2	186,5	147,2
	4+4	--	--	166,2	113,8	256,8	204,4	313	260,6	347,4	295	438	385,6	528,6	476,2	248,6	196,2
	5+5	--	--	117,1	51,6	207,7	142,2	263,9	198,4	298,3	232,8	388,9	323,4	479,5	414	310,8	245,3
	7+5	--	--	--	--	158,7	80,1	214,9	136,3	249,3	170,7	339,9	261,3	430,5	351,9	372,9	294,3
UT55	2+2	243,2	194,4	364,0	315,2	484,8	436	557,3	508,5	605,6	556,8	726,4	677,6	847,2	798,4	167,9	119,1
	3+3	183,6	110,5	304,0	231,3	425,2	352,1	497,7	424,6	546	472,9	666,8	593,7	787,6	714,5	251,8	178,7
	4+4	124,0	26,6	244,8	147,4	365,6	268,2	438,1	340,7	486,4	389	607,2	509,8	728	630,6	335,7	238,3
	5+5	--	--	185,3	63,4	306,1	184,2	378,6	256,7	426,8	305	547,7	425,8	668,5	546,6	419,7	297,8
	7+5	--	--	--	--	246,5	100,3	319	172,8	367,3	221,1	488,1	341,9	608,9	462,7	503,6	357,4
UT 60	2+2	356,5	307,4	539,7	490,6	722,9	763,8	836,5	787,4	906,1	857	1089,3	1040,2	1272,5	1223,4	242,2	193,1
	3+3	260,0	186,2	443,2	369,4	626,4	552,6	740	666,2	812,6	735,8	992,8	919	1176	1102,2	363,4	289,6
	4+4	163,4	65,1	346,6	248,3	529,8	431,5	643,4	545,1	713	614,7	896,2	797,9	1079,4	981,1	484,5	386,2
	5+5	--	--	250,1	127,2	433,3	310,4	546,9	424	616,5	493,6	799,7	676,8	982,9	860	605,6	482,7
	7+5	--	--	153,5	6,2	336,7	189,4	450,3	303	519,9	372,6	703,1	555,8	886,3	739	726,6	579,3
UT 65	2+2	489,6	404,7	731,2	649,3	972,8	890,9	1122,6	1040,7	1214,4	1132,5	1456,6	1374,1	1697,6	1615,5	317,1	235,2
	3+3	372	249,1	613,6	490,7	855,2	732,3	1005	882,1	1096,8	973,9	1338,4	1215,5	1580	1457,1	475,7	352,8
	4+4	254,3	90,6	495,9	332,2	737,5	573,8	887,3	723,6	979,1	815,4	1220,7	1057	1462,3	1298,6	634,2	470,5
	5+5	--	--	378,3	173,6	619,9	415,2	769,7	565	861,5	656,8	1103,1	898,4	1344,7	1140	792,8	588,1
	7+5	--	--	260,8	14,8	502,4	256,4	652,2	406,2	744	498	985,6	739,6	1227,2	981,2	951,6	705,6
UT 70	2+2	1073	940	1546	1413	2019	1886	2312	2179	2492	2359	2965	2832	3438	3305	479	346
	3+3	900	700	1373	1173	1846	1646	2139	1939	2319	2119	2792	2592	3265	3065	719	519
	4+4	727	461	1200	934	1673	1407	1966	1700	2146	1880	2619	2353	3092	2826	958	692
	5+5	--	--	1026	694	1499	1167	1792	1460	1972	1640	2445	2113	2918	2586	1198	866
	6+6	--	--	853t	454	1326	927	1619	1220	1799	1400	2272	1873	2745	2346	1438	1039
	7+7	--	--	--	--	1153	688	1446	981	1626	1161	2099	1634	2572	2107	1677	1212
	8+8	--	--	--	--	--	--	1273	741	1453	921	1926	1394	2399	1867	1917	1385
	UT 75	2+2	1500	1261	2134	1895	2768	2529	3161	2922	3402	3163	4036	3797	4671	4432	642
3+3	1299	940	1933	1574	2567	2208	2960	2601	3201	2842	3835	3476	4470	4111	936	604	
4+4	1098	619	1732	1253	2366	1887	2759	2280	3000	2521	3634	3155	4269	3790	1284	805	
5+5	--	--	1530	933	2164	1567	2557	1960	2798	2201	3432	2835	4067	3470	1604	1007	
6+6	--	--	1329	612	1963	1246	2356	1639	2597	1880	3231	2514	3866	3149	1925	1208	
7+7	--	--	--	--	1761	925	2154	1318	2395	1559	3029	2193	3664	2828	2246	1410	
8+8	--	--	--	--	1560	604	1953	997	2194	1238	2828	1872	3463	2507	2567	1611	

Pneumatic actuators - dimensions

UT 10 - UT 65

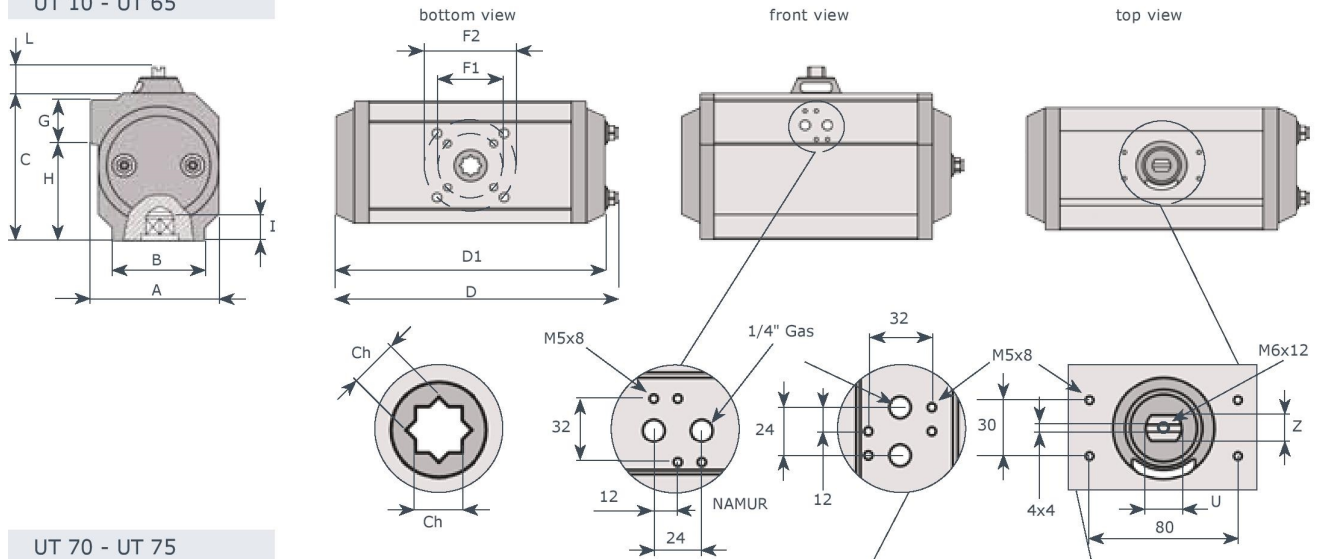

UT 70 - UT 75

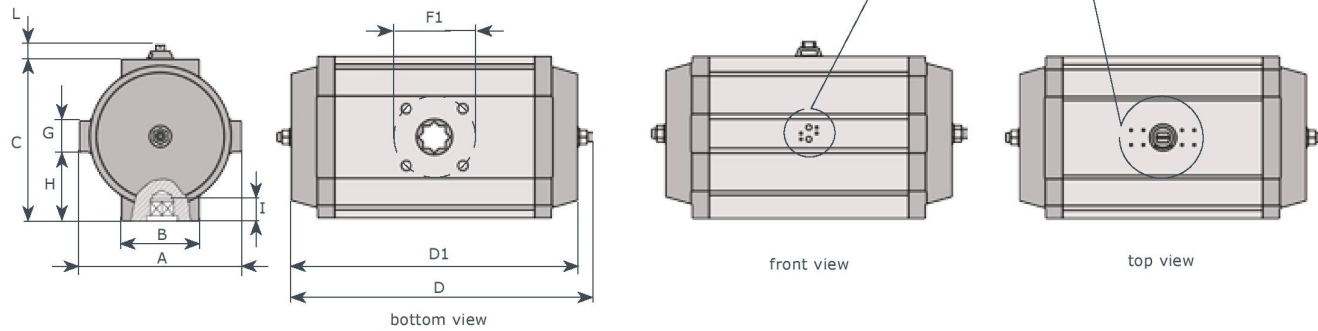

tipo/type	A	B	C	D	D1	F1	F2	G	H	I	Ch	L	U	Z
UT10	-	53	71	119	-	-	F03	45	26	12,5	11	20	12/14	9/11
UT15	81	62	81	175	165	F05	F07	45	36	19	14	30	12	10
UT17	81	62	81	207	197	F05	F07	45	36	19	14	30	12	10
UT20	96	76,5	98	186	177	F05	F07	45	53	19	17	30	14	10
UT25	96	76,5	98	248	239	F05	F07	45	53	23	17	30	14	10
UT30	114	90,5	117	241	230	F05	F07	45	72	23	17	30	19,5	14
UT35	131	95,5	154	261	246	F07	F10	45	109	30	22	30	19,5	14
UT40	131	95,5	154	305	290	F07	F10	45	109	30	22	30	19,5	14
UT45	145	98,5	168,5	367	351	F07	F10	45	123,5	30	22	30	28	20
UT50	181	124,5	202	380,5	361	F10	F12	45	157	31	27	30	28	20
UT55	181	124,5	202	428	418	F10	F12	45	157	37	27	30	28	20
UT60	232	140	274	467	444	F10	F14	45	212	41	36	30	28	20
UT65	232	140	274	525	502	F10	F14	45	212	50	36	30	28	20
UT70	332	160	332	636	587	F16	//	55	283	64	46	30	45	36
UT75	332	160	332	734	677	F16	//	55	283	64	46	30	45	36

Weight and air consumption - full cycle

type	weight (kg)		air consumption (N Lt)		type	weight (kg)		air consumption (N Lt)	
	DA	SR	DA	SR		DA	SR	DA	SR
UT10	0.570	0.655	0.22	0.13	UT45	11.17	13.73	4.40	1.85
UT15	1.60	1.79	0.41	0.18	UT50	16.20	19,56	4.60	2.50
UT17	1.92	2.16	0.55	0.25	UT55	19.90	24.72	9.00	4.10
UT20	2.35	2.73	0.71	0.29	UT60	27.95	37.73	12.50	6.50
UT25	3.25	3.77	1.10	0.48	UT65	38.40	48.00	16.60	7.10
UT30	4.15	4.88	1.40	0.65	UT70	66.80	82.96	27.10	9.60
UT35	6.80	8.24	2.45	1.20	UT75	81.60	98.00	31.40	11.70
UT40	8.10	9.78	3.05	1.60					

Pneumatic actuators

Double - Single acting

double acting actuator - 5 ways solenoid valve

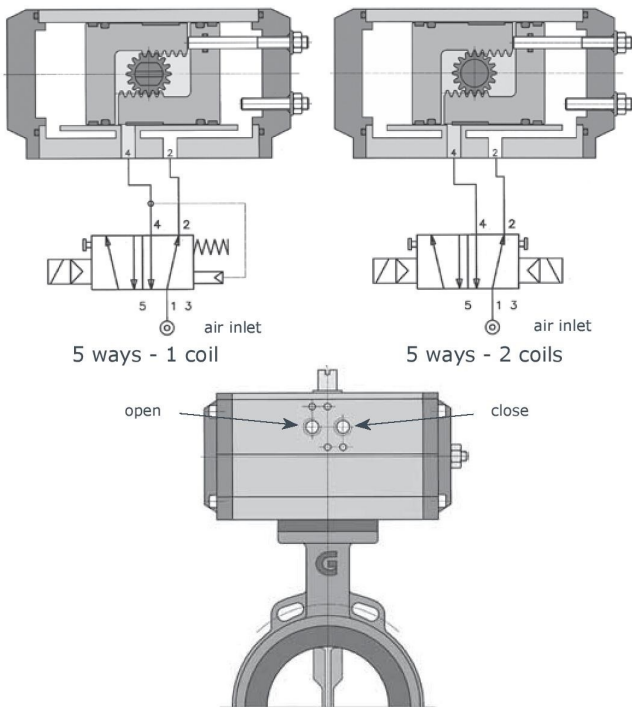

single acting actuator - 3 ways solenoid valve

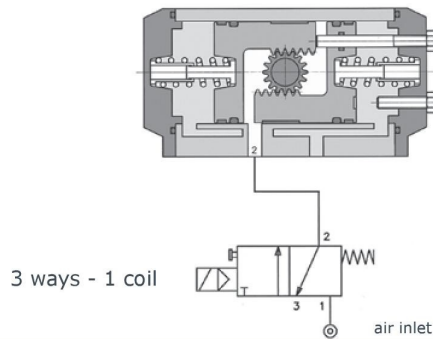
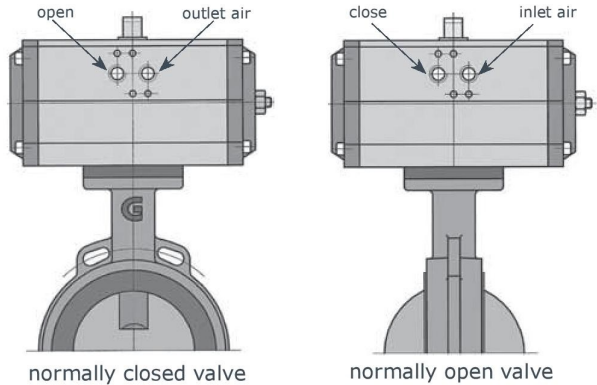

Adjustement of valve closing angle

butterfly valves are tested and supplied with a closing angle adjustment at +5°. In case this angle should be modified, operate as follows:

1. let the valve in semi-open position,
2. close compressed air supply,
3. loosen nut A,
4. rotate B screws anticlockwise to reduce closing angle, or clockwise to enlarge it,
5. tighten A nut, paying attention that C packing is not damaged,
6. re-connect compressed air and close the valve.

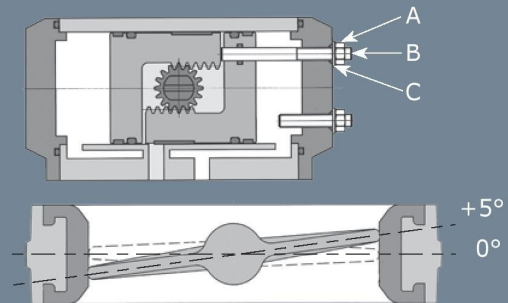

Options



IP65 NAMUR solenoid valves
 Namur coupling 3/5 ways 1/2 coils.
 Working pressure: min. 2 bar - max. 10 bar
 working temperature: -20°C +80°C
 Screw manual operation.

Standard voltage: 24V CC/CA-110V CA-220V CA
 Different voltages on request.
 Available also in explosion proof and intrinsically safe with ATEX certification.



IP67 BOXES
 Electromechanical switches
 SPDT 3A 250 VAC/3A 24 VDC
 NAMUR proximity switches
 P+F NJ4-12GK-N EEx ia IIC T6 2 wires not amplified
 P+F PNP NO NBN4-12GM 50 E2 3 wires amplified 10-30 DC 200 mA
 P+F NO NBN4 - 12GM40 ZO 2 wires amplified 6-60V DC 4-100 mA
 P+F SJ 3,5N 2 wires not amplified EEx ia II C T6

EXPLOSION-PROOF BOXES
 Electromechanical switches
 SPDT 5A 250VAC / 3A 24V DC
 NAMUR proximity switches
 P+F NJ4-12GK-N EEx ia IIC T6 2 wires not amplified
 P+F PNP NO NBN4-12GM 50 E2 3 wires amplified 10-30 DC 200 mA
 P+F NO NBN4 - 12GM40 ZO 2 wires amplified 6-60V DC 4-100 mA
 P+F SJ 3,5N 2 wires not amplified EEx ia II C T6



Pneumatic Positioner
 Electro-pneumatic positioner
 The positioner provides accurate positioning of butterfly valve disc. It can be used with 3-15 PSI, pneumatic control signal, or with 4-20 mA electric signal by means of the proper trasducer. Output signal can be 4-20 mA or of resistive type. Transmitter can be easily applied also on positioner already installed. Standard cam regulates rotation on a 90° angle with 3-15 PSI signal or 3-9 PSI or 9-15 PSI.

Electro-pneumatic position controller

Description

The positioner Type 8792 / 8793 is a digital, electro-pneumatic position controller for pneumatically actuated proportional valves. The device incorporates the main function groups:

- Position measuring system
- Electro-pneumatic control system
- Microprocessor electronics

Environmental temperature

0°C / +60 °C

Protection class

IP 65 / IP 67 according to EN 60529

Material:

- Housing material: Plastic-coated aluminium
- Other external parts: Stainless steel (V4A), PC, PE, POM, PTFE
- Sealing material: EPDM, NBR, FKM

Electrical data

- Power supply: 24 V DC ± 10% max. residual ripple 10%
- Power consumption: < 5 W

Pneumatic data

- Temperature range: compr. air 0/+60 °C
- Pressure range 1.4 – 7 bar



The position measuring system measures the current positions of the proportional valve. The microprocessor electronics continuously compare the current position (actual value) with a set-point position value specified via the unit signal input and supplies the result to the position controller.

Other features:

- mass: approx. 1.0 kg

Versions:

- position controller function (Type 8792)
- process controller function (Type 8793)

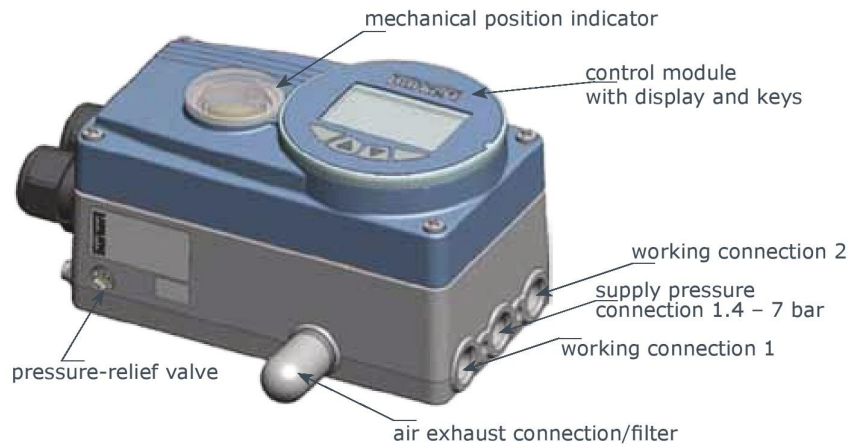

Type 8792
position controller function

The position of the actuator is regulated according to the position set-point value. The position set-point value is specified by an external uniform signal (or via field bus).

Type 8793
process controller function

The positioner Type 8793 also features a PID controller which, apart from actual position control, can also be used to implement process control (e.g. level, pressure, flow rate, temperature) in the sense of a cascade control. The positioner Type 8793 is operated with a 128 x 64 dot matrix graphics display and a keypad with 4 keys. The positioner is linked to a control circuit. The position set-point value of the valve is calculated from the process set-point value and the actual process value via the control parameters (PID controller). The process set-point value can be set by an external signal.

Coupling SOFT SEATED valve - actuator DA / DOUBLE ACTING

valve seat: EPDM/NBR		fluid: H ₂ O		T: 20°C				operating air pressure: ≥5.5 bar					
DN	"	PD series		KI series				KA series		KX series			
		mod.	G	P=6 B	G	P=10 B	G	P=16 B	G	mod.	G	mod.	G
40	1 ^{1/2}	≈	≈	UT 15	16	UT 15	16	UT 15	16	UT 15	16	≈	≈
50	2	UT 15	16	UT 15	16	UT 15	16	UT 15	16	UT 15	16	UT 15	16
65	2 ^{1/2}	UT 15	16	UT 15	16	UT 15	16	UT 15	16	UT 15	16	UT 20	16
80	3	UT 15	16	UT 17	16	UT 20	16	UT 20	16	UT 20	16	UT 25	16
100	4	UT 15	16	UT 20	16	UT 25	16	UT 25	16	UT 25	16	UT 25	16
125	5	UT 17	16	UT 25	16	UT 25	16	UT 30	16	UT 30	16	UT 30	16
150	6	UT 25	16	UT 25	16	UT 30	16	UT 30	16	UT 30	16	UT 35	16
200	8	UT 25	14	UT 35	14	UT 40	14	UT 45	14	UT 45	14	UT 50	14
250	10	UT 35	14	UT 40	14	UT 45	14	UT 50	14	UT 50	14	UT 55	14
300	12	UT 40	14	UT 45	14	UT 50	14	UT 55	14	UT 55	14	≈	≈
350	14	UT 50	100	UT 55	100	UT 60	100	UT 65	100	UT 65	100	≈	≈
400	16	UT 50	100	UT 55	100	UT 60	100	UT 65	100	UT 70	100	≈	≈
450	18	UT 55	100	UT 55	100	UT 60	100	UT 65	100	UT 70	100	≈	≈
500	20	UT 60	100	UT 60	100	UT 60	100	UT 70	100	on req.	#	≈	≈
600	24	≈	≈	UT 70	100	UT 75	100	on req.	#	on req.	#	≈	≈
700	28	≈	≈	UT 75	150	on req.	#	on req.	#	on req.	#	≈	≈
800	32	≈	≈	on req.	#	on req.	#	on req.	#	on req.	#	≈	≈

valve seat: EPDM/NBR		fluid: Air		T:20°C				operating air pressure: ≥5.5 bar					
valve seat: FKM		fluid: H ₂ O		KI series									
DN	"	PD series		KI series									
		mod.	G	P=6 B	G	P=10 B	G	P=16 B	G				
40	1 ^{1/2}	≈	≈	UT 15	16	UT 15	16	UT 15	16	UT 15	16		
50	2	UT 15	16	UT 15	16	UT 15	16	UT 15	16	UT 17	16		
65	2 ^{1/2}	UT 15	16	UT 17	16	UT 17	16	UT 17	16	UT 17	16		
80	3	UT 15	16	UT 20	16	UT 25	16	UT 25	16	UT 25	16		
100	4	UT 15	16	UT 25	16	UT 30	16	UT 30	16	UT 30	16		
125	5	UT 20	16	UT 30	16	UT 35	16	UT 35	16	UT 35	16		
150	6	UT 25	16	UT 30	16	UT 35	16	UT 35	16	UT 40	16		
200	8	UT 30	14	UT 35	14	UT 50	14	UT 50	14	UT 50	14		
250	10	UT 35	14	UT 45	14	UT 50	14	UT 50	14	UT 60	50		
300	12	UT 45	14	UT 50	14	UT 60	50	UT 60	50	UT 60	50		
350	14	UT 55	100	UT 60	100	UT 65	100	UT 65	100	UT 70	100		
400	16	UT 60	100	UT 60	100	UT 70	100	UT 70	100	UT 70	100		
450	18	UT 60	100	UT 65	100	UT 70	100	UT 70	100	UT 70	100		
500	20	UT 60	100	UT 65	100	UT 75	100	UT 75	100	UT 75	100		
600	24	≈	≈	on req.	#	on req.	#	on req.	#	on req.	#		
700	28	≈	≈	on req.	#	on req.	#	on req.	#	on req.	#		
800	32	≈	≈	on req.	#	on req.	#	on req.	#	on req.	#		

valve seat: EPDM/NBR		fluid: H ₂ O		T: 20°C				operating air pressure: 4-5 bar					
DN	"	PD series		KI series				KA series		KX series			
		mod.	G	P=6 B	G	P=10 B	G	P=16 B	G	mod.	G	mod.	G
40	1 ^{1/2}	≈	≈	UT 15	16	UT 15	16	UT 15	16	UT 15	16	≈	≈
50	2	UT 15	16	UT 15	16	UT 15	16	UT 15	16	UT 15	16	UT 17	16
65	2 ^{1/2}	UT 15	16	UT 15	16	UT 15	16	UT 17	16	UT 17	16	UT 20	16
80	3	UT 15	16	UT 20	16	UT 25	16	UT 25	16	UT 25	16	UT 30	16
100	4	UT 15	16	UT 25	16	UT 25	16	UT 30	16	UT 30	16	UT 35	16
125	5	UT 20	16	UT 30	16	UT 30	16	UT 35	16	UT 35	16	UT 35	16
150	6	UT 30	16	UT 30	16	UT 35	16	UT 35	16	UT 35	16	UT 40	14
200	8	UT 30	14	UT 35	14	UT 45	14	UT 50	14	UT 50	14	UT 55	14
250	10	UT 35	14	UT 45	14	UT 50	14	UT 55	14	UT 55	14	UT 60	50
300	12	UT 45	14	UT 55	14	UT 55	14	UT 60	50	UT 60	50	on req.	#
350	14	UT 55	100	UT 60	100	UT 65	100	UT 70	100	UT 70	100	on req.	#
400	16	UT 60	100	UT 65	100	UT 65	100	UT 70	100	UT 75	100	on req.	#
450	18	UT 60	100	UT 65	100	UT 65	100	UT 75	100	on req.	#	on req.	#
500	20	UT 60	100	UT 65	100	UT 70	100	UT 75	100	on req.	#	on req.	#
600	24	≈	≈	on req.	#	on req.	#	on req.	#	on req.	#	on req.	#
700	28	≈	≈	on req.	#	on req.	#	on req.	#	on req.	#	on req.	#
800	32	≈	≈	on req.	#	on req.	#	on req.	#	on req.	#	on req.	#

Coupling SOFT SEATED valve - actuator SR / SINGLE ACTING

valve seat: EPDM/NBR		fluid: H ₂ O		T: 20°C				operating air pressure: ≥5.5 bar					
DN	"	PD series		KI series				KA series		KX series			
		mod.	G	P=6 B	G	P=10 B	G	P=16 B	G	mod.	G	mod.	G
40	1 ^{1/2}	≈	≈	UTS 15	16	UTS 15	16	UTS 15	16	UTS 20	16	≈	≈
50	2	UTS 15	16	UTS 15	16	UTS 15	16	UTS 15	16	UTS 20	16	UTS 20	16
65	2 ^{1/2}	UTS 15	16	UTS 17	16	UTS 17	16	UTS 20	16	UTS 25	16	UTS 30	16
80	3	UTS 15	16	UTS 25	16	UTS 30	16	UTS 30	16	UTS 30	16	UTS 35	16
100	4	UTS 15	16	UTS 30	16	UTS 30	16	UTS 35	16	UTS 35	16	UTS 40	16
125	5	UTS 25	16	UTS 35	16	UTS 35	16	UTS 40	16	UTS 40	16	UTS 40	16
150	6	UTS 35	16	UTS 35	16	UTS 45	16	UTS 45	16	UTS 45	16	UTS 45	16
200	8	UTS 35	14	UTS 45	14	UTS 50	14	UTS 55	14	UTS 55	14	UTS 60	50
250	10	UTS 45	14	UTS 50	14	UTS 55	14	UTS 60	50	UTS 60	50	UTS 65	50
300	12	UTS 50	14	UTS 60	14	UTS 60	50	UTS 60	50	UTS 65	50	≈	≈
350	14	UTS 60	100	UTS 65	100	UTS 70	100	UTS 75	100	UTS 75	100	≈	≈
400	16	UTS 60	100	UTS 65	100	UTS 70	100	UTS 75	100	on req.	#	≈	≈
450	18	UTS 70	100	UTS 70	100	UTS 70	100	UTS 75	100	on req.	#	≈	≈
500	20	UTS 70	100	UTS 70	100	UTS 75	100	su ric.	#	on req.	#	≈	≈
600	24	≈	≈	on req.	#	on req.	#	on req.	#	on req.	#	≈	≈
700	28	≈	≈	on req.	#	on req.	#	on req.	#	on req.	#	≈	≈
800	32	≈	≈	on req.	#	on req.	#	on req.	#	on req.	#	≈	≈

valve seat: EPDM/NBR		fluid: Air		T:20°C				operating air pressure: ≥5.5 bar	
valve seat: FKM		fluid: H ₂ O		KI series					
DN	"	PD series		P=6 B		P=10 B		P=16 B	
		mod.	G	G	G	G	G	G	G
40	1 ^{1/2}	≈	≈	UTS 20	16	UTS 20	16	UTS 20	16
50	2	UTS 15	16	UTS 20	16	UTS 20	16	UTS 20	16
65	2 ^{1/2}	UTS 15	16	UTS 20	16	UTS 20	16	UTS 25	16
80	3	UTS 15	16	UTS 30	16	UTS 35	16	UTS 35	16
100	4	UTS 20	16	UTS 35	16	UTS 35	16	UTS 40	16
125	5	UTS 30	16	UTS 35	16	UTS 40	16	UTS 45	16
150	6	UTS 35	16	UTS 40	16	UTS 45	16	UTS 45	16
200	8	UTS 40	14	UTS 50	14	UTS 55	14	UTS 60	50
250	10	UTS 50	14	UTS 55	14	UTS 60	50	UTS 65	50
300	12	UTS 60	50	UTS 60	50	UTS 65	50	UTS 70	100
350	14	UTS 70	100	UTS 70	100	UTS 70	100	UTS 75	100
400	16	UTS 70	100	UTS 70	100	UTS 70	100	on req.	#
450	18	UTS 70	100	UTS 70	100	UTS 70	100	on req.	#
500	20	UTS 70	100	UTS 70	100	UTS 75	100	on req.	#
600	24	on req.	#	on req.	#	on req.	#	on req.	#
700	28	on req.	#	on req.	#	on req.	#	on req.	#
800	32	on req.	#	on req.	#	on req.	#	on req.	#

valve seat: EPDM/NBR		fluid: H ₂ O		T: 20°C				operating air pressure: 4-5 bar					
DN	"	PD series		KI series				KA series		KX series			
		mod.	G	P=6 B	G	P=10 B	G	P=16 B	G	mod.	G	mod.	G
40	1 ^{1/2}	≈	≈	UTS4 17	16	UTS4 20	16	UTS4 20	16	UTS4 20	16	≈	≈
50	2	UTS4 15	16	UTS4 17	16	UTS4 20	16	UTS4 20	16	UTS4 25	16	UTS4 25	16
65	2 ^{1/2}	UTS4 15	16	UTS4 20	16	UTS4 20	16	UTS4 25	16	UTS4 25	16	UTS4 30	16
80	3	UTS4 15	16	UTS4 30	16	UTS4 35	16	UTS4 35	16	UTS4 35	16	UTS4 35	16
100	4	UTS4 20	16	UTS4 35	16	UTS4 35	16	UTS4 35	16	UTS4 35	16	UTS4 40	16
125	5	UTS4 30	16	UTS4 40	16	UTS4 40	16	UTS4 45	16	UTS4 45	16	UTS4 45	16
150	6	UTS4 35	16	UTS4 40	16	UTS4 45	16	UTS4 45	16	UTS4 45	16	UTS4 50	16
200	8	UTS4 40	14	UTS4 50	14	UTS4 55	14	UTS4 60	50	UTS4 60	50	UTS4 65	50
250	10	UTS4 45	14	UTS4 55	14	UTS4 60	50	UTS4 65	50	UTS4 65	50	UTS4 70	100
300	12	UTS4 55	14	UTS4 60	50	UTS4 65	50	UTS4 70	100	UTS4 70	100	≈	≈
350	14	UTS4 70	100	UTS4 70	100	UTS4 70	100	UTS4 75	100	on req.	#	≈	≈
400	16	UTS4 70	100	UTS4 70	100	UTS4 75	100	UTS4 75	100	on req.	#	≈	≈
450	18	UTS4 70	100	UTS4 70	100	UTS4 75	100	su ric.	#	on req.	#	≈	≈
500	20	UTS4 70	100	UTS4 70	100	UTS4 75	100	su ric.	#	on req.	#	≈	≈
600	24	≈	≈	on req.	#	on req.	#	on req.	#	on req.	#	≈	≈
700	28	≈	≈	on req.	#	on req.	#	on req.	#	on req.	#	≈	≈
800	32	≈	≈	on req.	#	on req.	#	on req.	#	on req.	#	≈	≈

Coupling PTFE SEATED valve - pneumatic actuators - **UT series**

Valve seat: PTFE - Fluid: H2O - T: 20° C air: 5,5 Bar

DN	M	DA type - double acting				SR type - single acting			
		P=6 B	G	P=10 B	G	P=6 B	G	P=10 B	G
50	138	UT 15	16	UT 15	16	UTS 20	16	UTS 20	16
65	144	UT 15	16	UT 15	16	UTS 20	16	UTS 25	16
80	158	UT 20	16	UT 20	16	UTS 30	16	UTS 35	16
100	173	UT 25	16	UT 25	16	UTS 35	16	UTS 35	16
125	186	UT 25	16	UT 25	16	UTS 35	16	UTS 35	16
150	202	UT 25	16	UT 30	16	UTS 35	16	UTS 35	16
200	240	UT 35	14	UT 40	14	UTS 50	14	UTS 50	14
250	270	UT 45	14	UT 50	14	UTS 55	14	UTS 60	50
300	300	UT 50	14	UT 50	14	UTS 60	50	UTS 60	50
350	330	UT 60	100	≈	≈	UTS 70	100	≈	≈
400	355	UT 65	100	≈	≈	UTS 75	100	≈	≈
500	422	UT 70	100	≈	≈	UTS 75	100	≈	≈

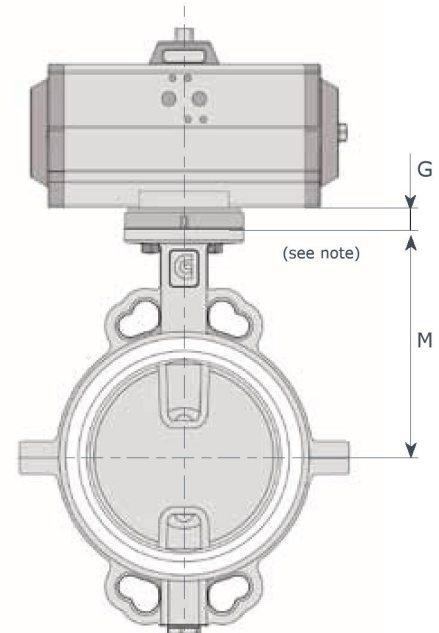

G dimension can change depending on valve/actuator coupling. Pls refer to coupling tables.

Coupling **DOUBLE ECCENTRIC** valve (**HD series**) - pneumatic actuator

Fluid: H2O - T: 20° C - P air: 5,5 Bar - Seat: RTFE

DN	M	PN 16				PN 25			
		DA		SR		DA		SR	
		mod.	G	mod.	G	mod.	G	mod.	G
50	117	UT 20	50	UTS 30	50	UT 25	50	UTS 35	50
65	120	UT 20	50	UTS 30	50	UT 25	50	UTS 35	50
80	129	UT 25	50	UTS 35	50	UT 30	50	UTS 40	50
100	160	UT 25	50	UTS 40	50	UT 35	50	UTS 45	50
125	170	UT 35	50	UTS 45	50	UT 35	50	UTS 50	50
150	179	UT 40	50	UTS 50	50	UT 45	50	UTS 55	50
200	218	UT 45	100	UTS 60	100	UT 50	100	UTS 65	100
250	257	UT 55	100	UTS 65	100	UT 60	100	UTS 70	100
300	300	UT 60	100	UTS 70	100				

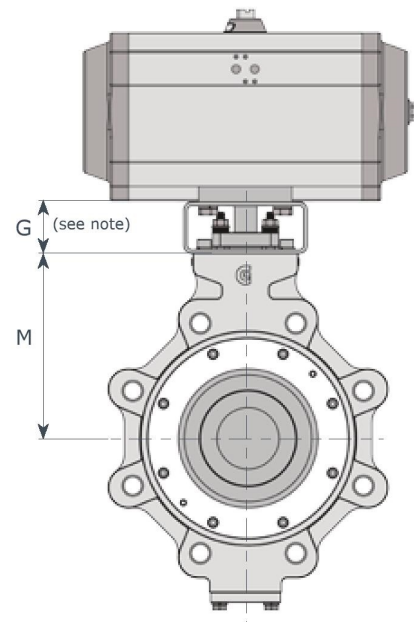

G dimension can change depending on valve/actuator coupling. Pls refer to coupling tables.

Coupling BV/BFFA valve (hot air and smoke) - pneumatic actuators - **UT series**

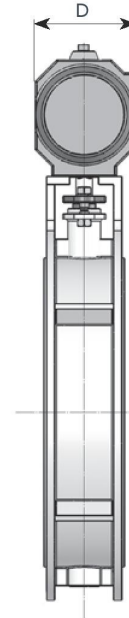
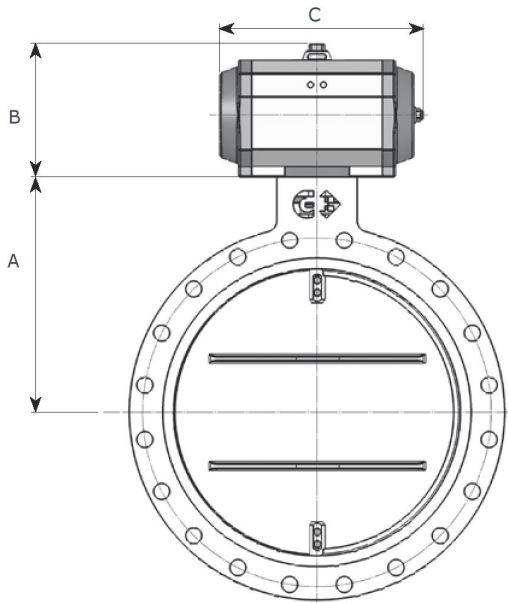

DN	A
50	120
65	130
80	155
100	163
125	195
150	214
200	268
250	277
300	290
350	315
400	360
450	386
500	410
600	486
700	535
800	605
900	675
1000	730

DN	Double acting actuator				Single acting actuator			
	type	B	C	D	type	B	C	D
50	UT 15	120	165	85	UTS17	120	197	85
65	UT 15	120	165	85	UTS17	120	197	85
80	UT 15	120	165	85	UTS17	120	197	85
100	UT 15	120	165	85	UTS17	120	197	85
125	UT 15	120	165	85	UTS17	120	197	85
150	UT 15	120	165	85	UTS17	120	197	85
200	UT 15	120	165	85	UTS20	142	177	96
250	UT 17	120	197	85	UTS25	142	239	96
300	UT 17	120	197	85	UTS30	161	230	113
350	UT 20	142	177	96	UTS35	195	246	138
400	UT 25	142	239	96	UTS35	195	246	138
450	UT 35	195	246	138	UTS35	195	246	138
500	UT 35	195	246	138	UTS35	195	246	138
600	UT 35	195	246	138	UTS35	195	246	138
700	UT 35	195	246	138	UTS40	195	290	138
800	UT 35	195	246	138	UTS40	195	290	138
900	UT 40	195	290	138	UTS45	207	351	151
1000	UT 40	195	290	138	UTS45	207	351	151

Declutchable manual gearboxes: aluminium - GD serie

A declutchable manual gear should be inserted between valve and actuator, in order to secure valve operation in case of emergency.

In normal conditions, the gearbox is declutched so that the handwheel does not rotate when working the actuator.

In case of emergency (air failure) the gearbox can be easily engaged by means of the side lever and the valve can be easily operated by means of the handwheel.

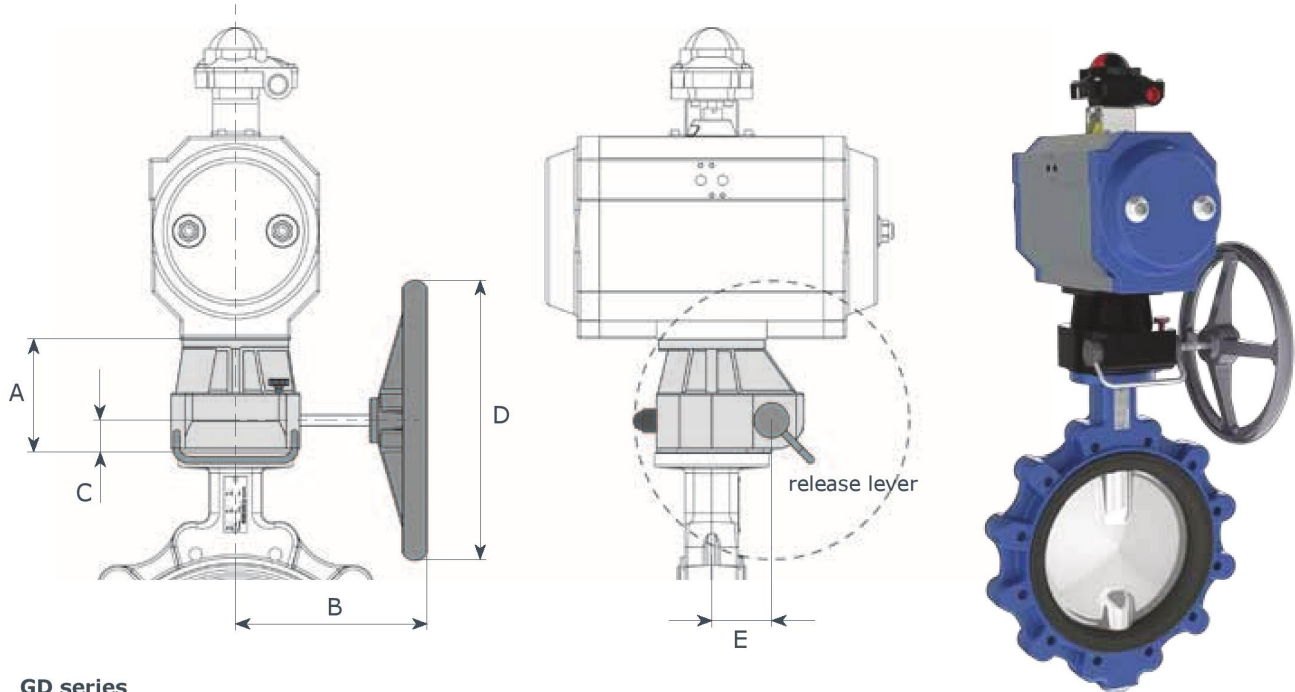

GD series

body:	aluminium	handwheel:	steel
worm gears:	steel	protection:	IP65
sector gear:	ductile iron	T:	-20 / +120 °C
shaft:	stainless steel		

	A	B	C	D	E	gear ratio	output Nm	weight Kg
GD070	118	150	34	200	52.2	1:38	470	3.5
GD102	125	180	35,5	300	65	1:36	810	5.6
GD140	162	300	50	400	85	1:50	1310	12.5
GD165	181	395	61	600	105	1:55	2800	22.5
GD254	205	400	80	700	130	1:52	5500	26

Ø valve	DA actuator double action	SR actuator spring return	emergency gearbox type
DN 40÷150	UT 20÷45	UTS 20÷35	GD070
DN 40÷300	UT 35÷55	UTS 35÷50	GD102
DN 200÷400	UT 50÷65	UTS 55÷65	GD140
DN 450÷600	UT 60	UTS 70÷75	GD165
DN 600÷800	UT 70÷75	≈	GD254

Emergency lever (only double acting)

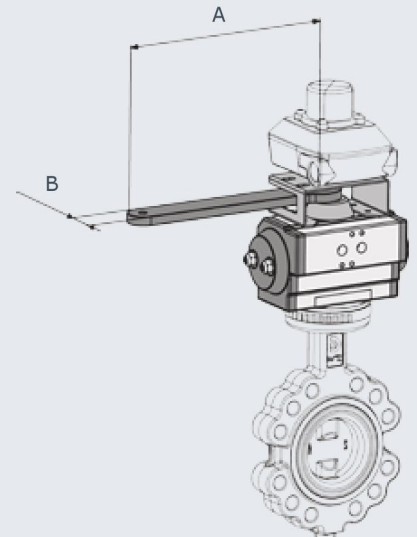

	A	B
UT10 ÷ UT20	218	35
UT25 ÷ UT35	218	35
UT40 ÷ UT50	385	40

Declutchable manual gearboxes: Cast Iron - ILGD serie

A declutchable manual gear should be inserted between valve and actuator, in order to secure valve operation in case of emergency.

In normal conditions, the gearbox is declutched so that the handwheel does not rotate when working the actuator.

In case of emergency (air failure) the gearbox can be easily engaged by means of the side lever and the valve can be easily operated by means of the handwheel.

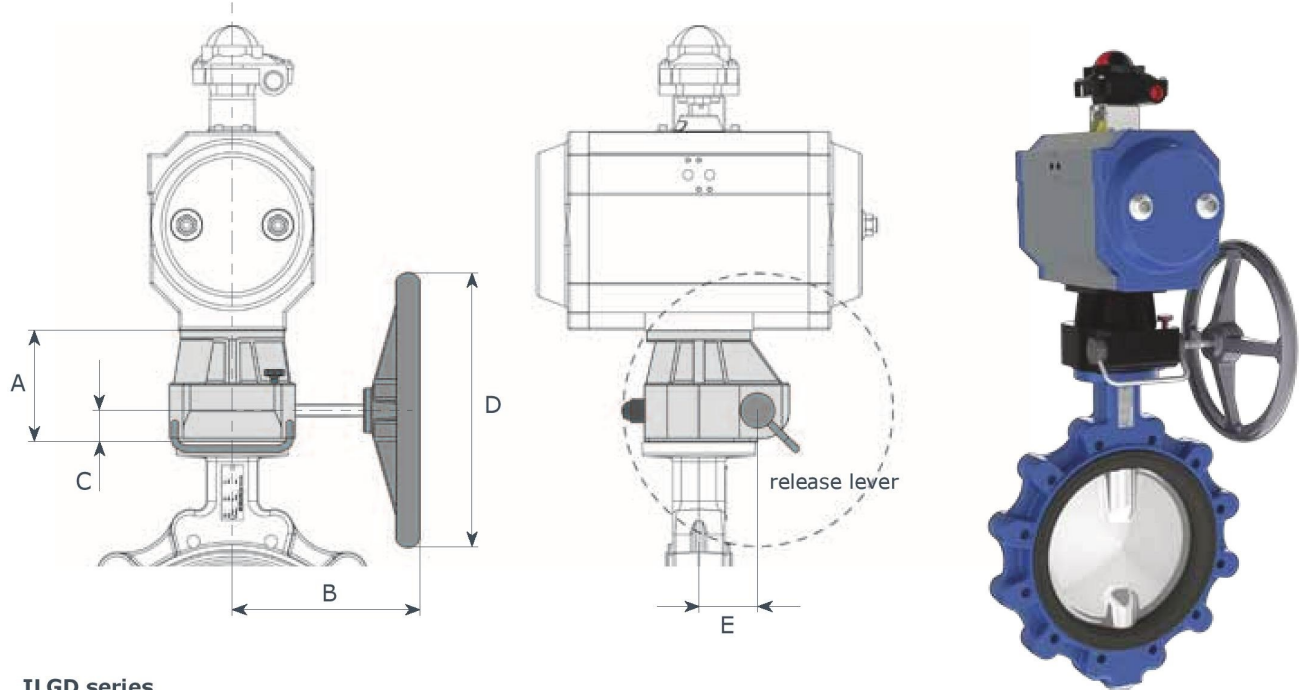

ILGD series

body: cast iron GG25
 worm gears: steel
 sector gear: ductile iron
 shaft: steel

handwheel: steel
 protection: IP65 (on req.)
 T: -20 / +120 °C

	A	B	C	D	E	gear ratio	output Nm	weight Kg
ILGD 200	122	208	42	125	53.2	1:35	250	7.3
ILGD 600	145	260	51	250	64.5	1:46	750	17
ILGD 900	160	290	56.5	400	84.5	1:45	1450	21
ILGD 1500	175	333	55	400	107.5	1:57	2485	34
ILGD 2400	194	364	62	DN 450-500: 600 DN 600: 700	127	1:68	3390	54
ILGD 5000	209	406	72	800	155	1:104	7450	80

Ø valve	DA actuator double action	SR actuator spring return	emergency gearbox type
DN 40÷150	UT 15÷45	UTS 15÷35	ILGD 200
DN 40÷300	UT 35÷55	UTS 35÷55	ILGD 600
DN 200÷400	UT 50÷65	UTS 50÷65	ILGD 900
DN 350÷600	UT 70	UTS 70	ILGD 1500
DN 450÷600	UT 75	UTS 70÷75	ILGD 2400
DN 600÷800	UT 70÷75	≈	ILGD 5000

Emergency lever (only double acting)

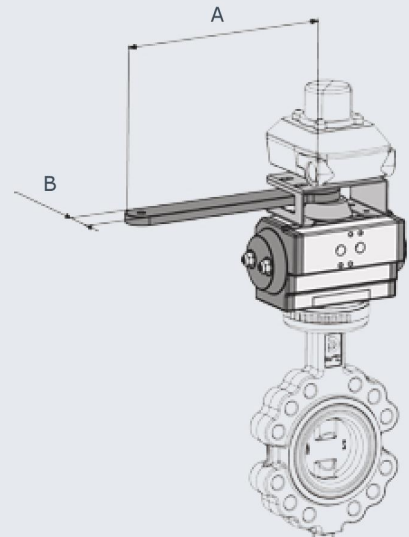

	A	B
UT10 ÷ UT20	218	35
UT25 ÷ UT35	218	35
UT40 ÷ UT50	385	40

Electric actuators J+J

"L series" from 12 to 48 V CA / CC - "H series" from 80 to 240V CA / CC

Enclosure protection: **IP65**
 Supply: **electrical with alternate or direct current with same motor.**

Working temperature: **-20°C / +70°C**

- Electronic torque limiter with electric disconnection in case of block
- 2 limit switches
- 2 auxiliary signal switches
- Internal 4W heater resistance against condensate
- Position indicator
- Emergency manual operator with automatic motor power tripping
- Possibility of assembly of 4 - 20 mA electronic positioner (to be indicated when ordering)
- Isulation: CLASS B - Service S4 - Duty Range 75%



J3 35 "L series" 12÷24 V CA/CC - "H series" 80÷240 V CA/CC

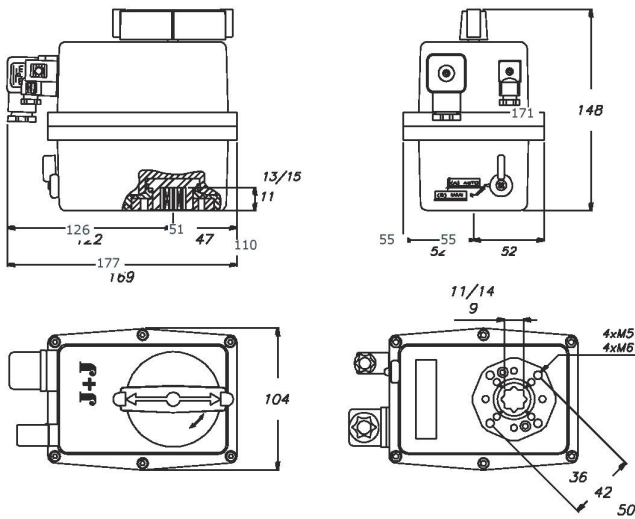

J3 55 "L series" 12÷24 V CA/CC - "H series" 80÷240 V CA/CC

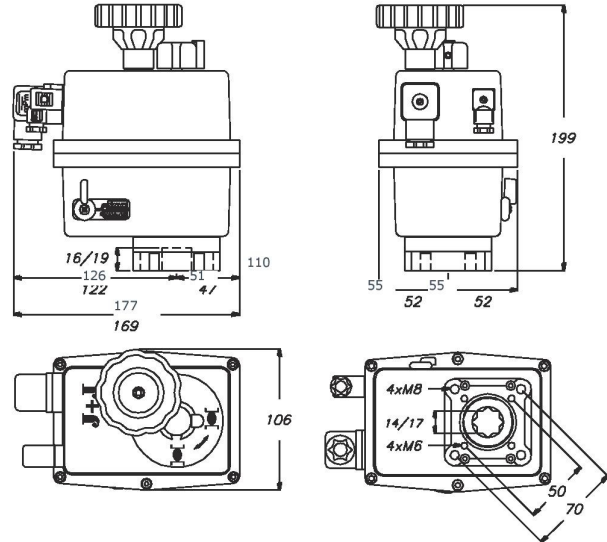

J2 140 - J2 300 "L series" 12÷48 V CA/CC - "H series" 80÷240 V CA/CC

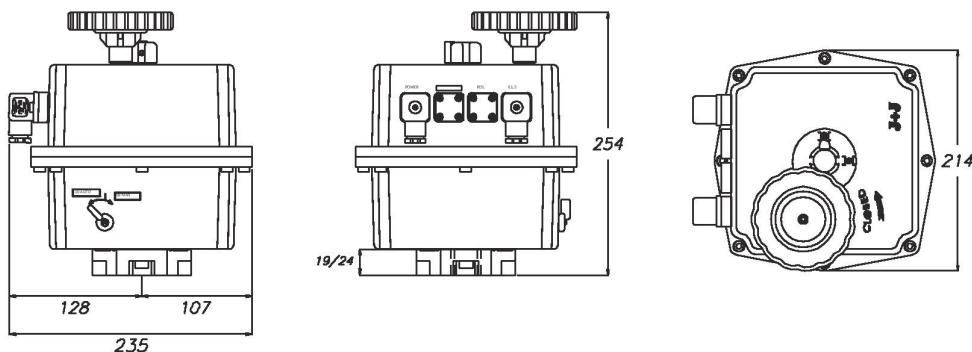

Electric actuators J+J

DPS 2005 - digital positioner

DPS 2005 is a device for the J3 electric actuator that changes the actuator into a valve positioner servo controlled. DPS 2005 is a modulus with a microprocessor (CPU) which digitally manages the analogical input and output and compares them with the position of the actuator to establish an uniform relation.

The analogical inputs are sent to CPU where they are processed for continuous checking of the position of the actuator, this allows a very high sensitivity and a very high repetitivity of the position (see characteristics).

DPS 2005 in communication with the electronic system of the actuator provides an integral management of the motion on the actuator. DPS 2005 is available for "H series" and "L series".

INPUT SIGNAL

4 – 20 mA / 0 – 10 V

OUTPUT SIGNAL

4 – 20 mA / 0 – 10 V

PRECISION

better than 1%

SETTINGS

max. – min.

LINEALITY

better than 1%

HYSTERESIS

better than 1%

Coupling valve **SOFT SEATED** - electric actuators J+JValve seat: **EPDM/NRB**fluid: **H₂O**T: **20°C**

DN	P max	type	M	G
40	16	J3-35	100	16
50	16	J3-35	138	16
65	16	J3-35	144	16
80	16	J3-55	158	16
100	6	J3-55	173	16
	16	J2-140	173	16
125	16	J2-140	186	16
150	16	J2-140	202	16
200	6	J2-140	240	14
	16	J2-300	240	14
250	10	J2-300	270	14
300	6	J2-300	300	14

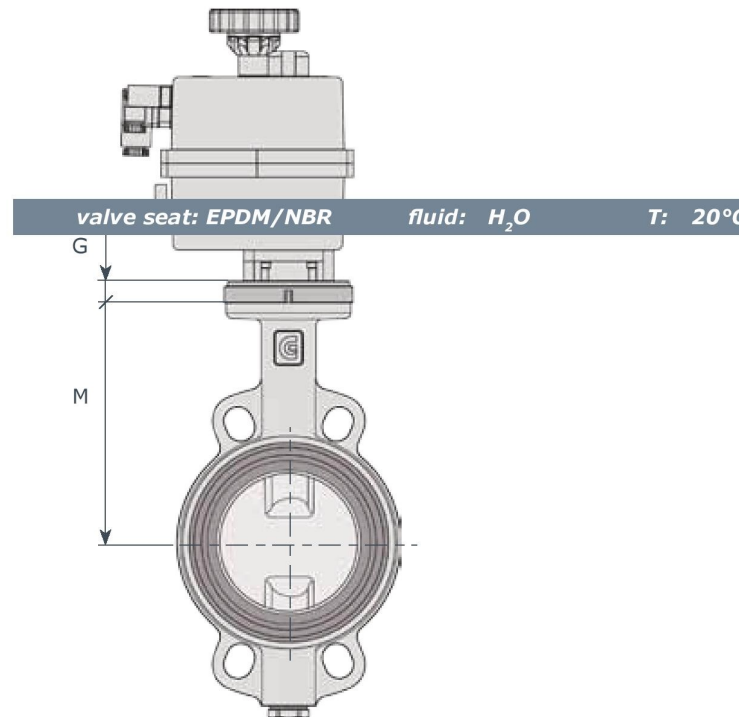

type	max torque Nm	closing time sec/90°	weight Kg	rated powers, Watts - Serie L				rated powers, Watts - Serie H	
				24 V CA	24 V CC	48 V CA	48 V CC	110 V	220 V
J3-35	38	12	1.8	25.7	35.8	--	--	25.4	26.6
J3-55	60	16	2	29.7	34.3	--	--	25.4	23.1
J2-140	170	33	5.2	86.4	72	62.4	48	77	50.6
J2-300	350	60	5.2	86.4	72	62.4	48	77	50.6

Electric actuators **Bernard**

Standard feature:

- Working temperature: -20°C / +70°C
- Enclosure protection: standard IP 67 (on request IP 68)
- Explosion-proof: (on request) type OA, AS, BS: EEx-de II CT 5 ATEX II 2G EEx-ed II BT 5
- Built-in heater resistance against condensate (6 - 10W acc. to DPDT)
- Tropicalized electric actuator F class insulated
- Electromechanical switches travel stop: 16A / 250VAC - 0.6A / 230 VDC SPDT type
- Lubrication "for life" (100.000 cycles).

Optional:

- Low temperature design: -30°C /+70°C
 - High temperature design: 0°C /+90°C
 - Design for marine service or nuclear plants
 - Declutchable handwheel (AS series not included)
 - Motor with winding insulation class H
 - Non-standard voltage:
 - » three phase max 690V
 - » single phase from 24V to 220V
 - » continuous from 24V to 220V
 - motor for positioning and modulating applications: duty S4 50%/100% up to 1800 starts per hour
 - additional limit switches
 - "INTEGRAL" control circuit: OPEN / STOP / CLOSE with remote/local selector switch
- Potentiometer for single or double indication: Standard 1000 Ohms, 4 Watt. Linearity +/- 0.25%
 - Potentiometer as above for modulating services
 - Posigam or Modugam type position transmitter: output signal 4 -20 mA for positioning or modulating
Input signal 4 -20 mA.



Standard internal wiring diagrams

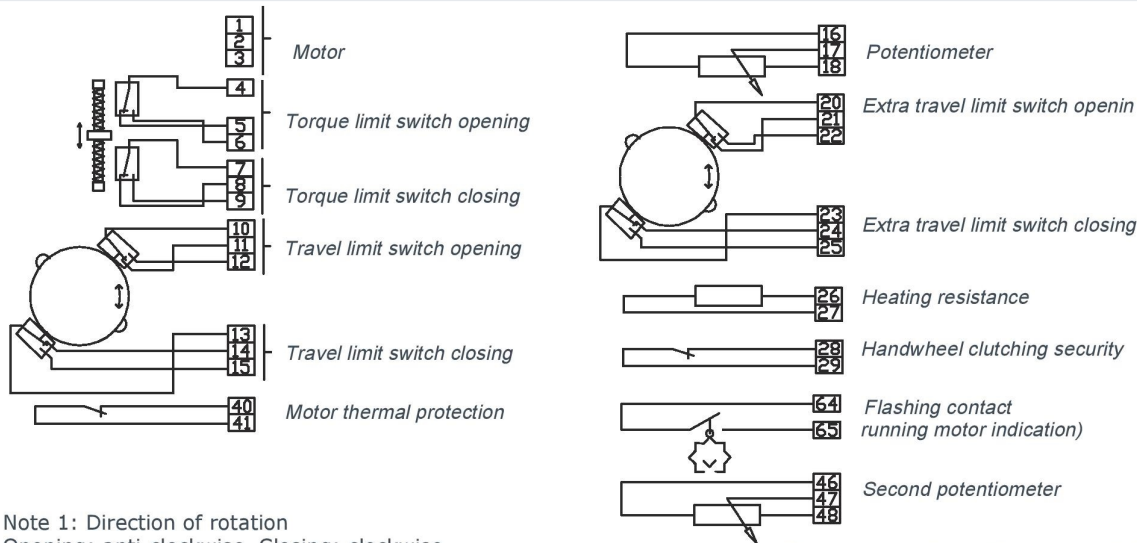

Note 1: Direction of rotation
Opening: anti-clockwise. Closing: clockwise

Note 2: Torque limit switches
Not available on OA model. Provide a short duration contact excepted specific configuration on request.

Note 3: Travel limit switches
Provide a maintained contact.

Position transmitter 4-20 mA model TAM

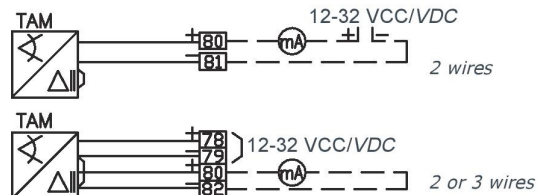

Technical features electric actuators **Bernard**

single phase motor 230V 50Hz										
model	max torque Nm	operating torque Nm	operating time s/90°	flange ISO	power Kw	speed rpm	current rated A	current start A	Cos φ	efficiency %
OA3	45	35	6	F05 / 07	0.03	1500	0.8	0.9	0.9	15
OA6	60	60	6	F05 / 07	0.03	1500	0.6	0.9	0.9	22
OA8	100	60	6	F05 / 07	0.06	1500	1.2	1.7	0.9	25
OAP	100	60	35	F05 / 07	0.02	1500	0.5	0.6	0.9	12
OA15	150	80	15	F07 / (10)	0.03	1500	0.6	0.9	0.9	22
AS18	200	140	5	F07 / 10	0.20	1500	2.5	3.5	0.9	36
ASP	250	140	30	F07 / 10	0.03	1500	0.6	0.9	0.9	22
AS25	250	140	5	F07 / 10	0.40	1500	4.0	6.3	0.9	41
AS50	600	400	30	F10 / 07	0.06	1500	1.2	1.7	0.9	25
AS80	800	400	30	F12	0.15	1500	2.0	3.0	0.9	35
three phase motor 400V 50 Hz										
model	max torque Nm	operating torque Nm	operating time s/90°	flange ISO	power Kw	speed rpm	current rated A	current start A	Cos φ	efficiency %
OA6	60	60	6	F05 / 07	0.03	1500	0.3	0.5	0.5	30
OA8	100	60	6	F05 / 07	0.10	1500	0.6	1.1	0.6	40
OAP	100	60	35	F05 / 07	0.03	1500	0.3	0.5	0.5	30
OA15	150	80	15	F07 / (10)	0.03	1500	0.3	0.5	0.5	30
AS18	200	140	5	F07 / 10	0.10	1500	0.6	1.1	0.6	40
ASP	250	140	30	F07 / 10	0.03	1500	0.3	0.5	0.5	30
AS25	250	140	5	F07 / 10	0.15	1500	0.7	2.1	0.6	58
AS50	600	400	30	F10 / 07	0.06	1500	0.3	0.8	0.8	35
AS80	800	400	30	F12	0.06	1500	0.3	0.8	0.8	35
AS100	1000	700	30	F12 / (14)	0.10	1500	0.6	1.2	0.6	43
AS200	2500	1700	70	F16 / (14)	0.10	1500	0.6	1.2	0.6	43
AS400	4000	3000	125	F16	0.10	1500	0.6	1.2	0.6	43
AS600	5800	2900	90	F25	0.14	3000	0.7	2.8	0.6	52
AS1000	10000	5000	90	F25	0.50	3000	1.6	5.0	0.9	53
single phase motor 115V 60Hz										
model	max torque Nm	operating torque Nm	operating time s/90°	flange ISO	power Kw	speed rpm	current rated A	current start A	Cos φ	efficiency %
OA3	45	35	5	F05 / 07	0.03	1800	1.5	1.8	0.9	21
OA6	60	60	5	F05 / 07	0.03	1800	1.9	2.5	0.9	18
OA8	100	60	5	F05 / 07	0.05	1800	2.2	4.3	0.9	40
OAP	100	60	30	F05 / 07	0.02	1800	1.1	1.6	0.9	13
OA15	150	80	13	F07 / 10	0.05	1800	1.9	2.5	0.9	18
ASP	250	140	25	F07 / 10	0.03	1800	1.3	2.0	0.9	23
AS25	250	140	4	F07 / 10	0.35	1800	6.0	19.0	0.9	57
AS50	600	400	25	F10 / 07	0.08	1800	2.2	4.3	0.9	40
AS80	800	400	25	F12	0.20	1800	4.0	17.0	0.9	48
motor 24 VDC										
model	max torque Nm	operating torque Nm	operating time s/90°	flange ISO	power Kw	speed rpm	current rated A	current start A	efficiency %	
OA6	60	60	6	F05 / 07	0.03	1500	2.5	8	46	
OAP	100	60	35	F05 / 07	0.03	1500	2.5	8	46	
OA15	150	80	15	F07 / 10	0.03	1500	2.5	8	46	
ASP	250	140	30	F07 / 10	0.03	1500	2.5	8	46	

Note: technical characteristics refer to standard electric actuators
 Pls consult our technical dpt for actuators with different requirements

OA 3 Type

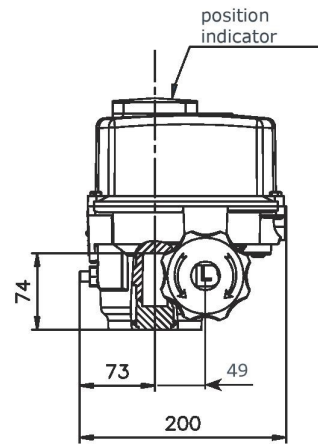
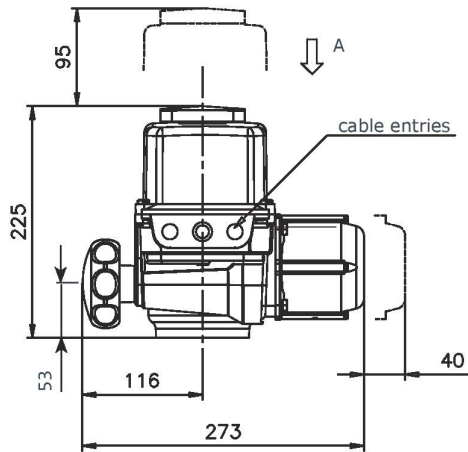

flange
ISO 5211
F05/F07

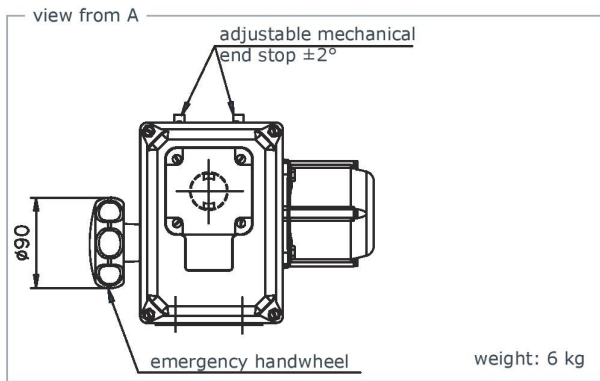

OA 6 - OA 8 - OAP - OA15 Type

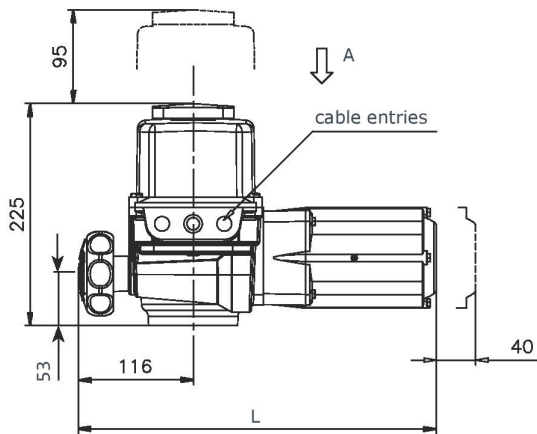

flange
ISO 5211
F05/F07

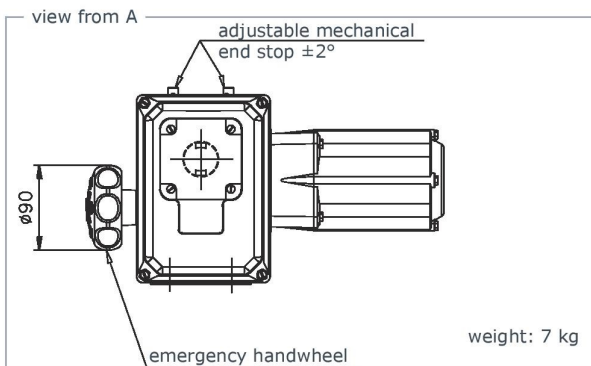
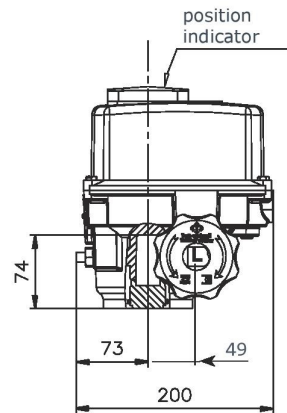

mod.	OA6	OA8	OAP	OA15
L	319	319	362	362

AS 18 - AS 25 - ASP Type

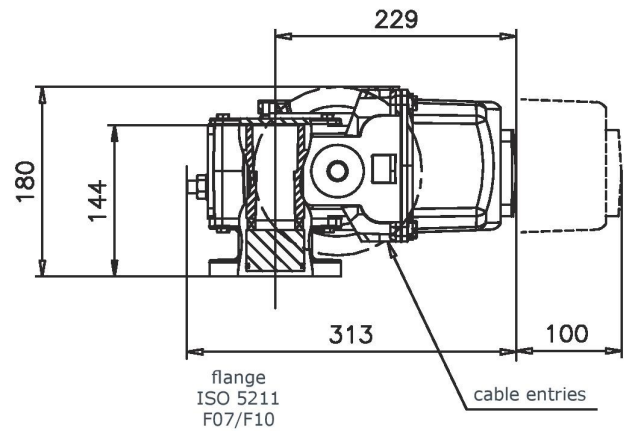
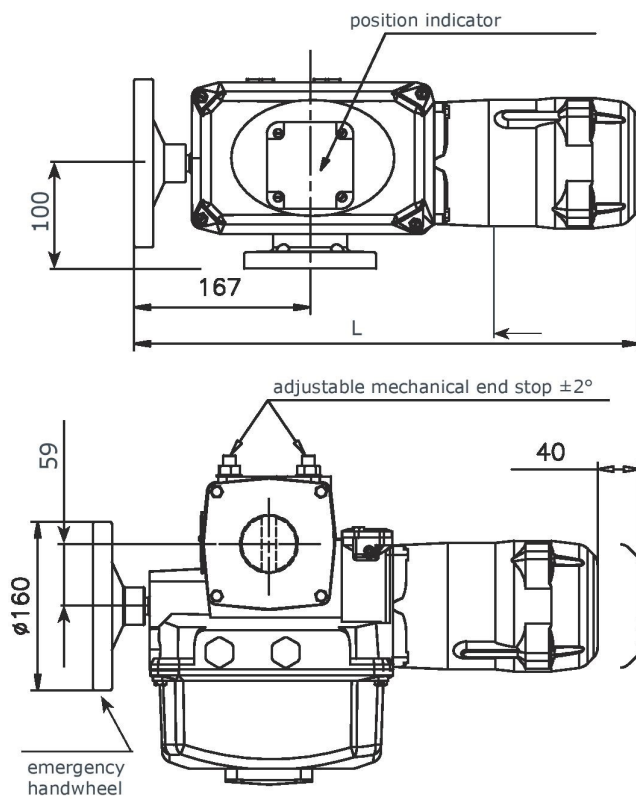

mod.	L	Kg
AS 18	479	18
AS 25	479	18
ASP	459	15

AS 50 - AS 80 Type

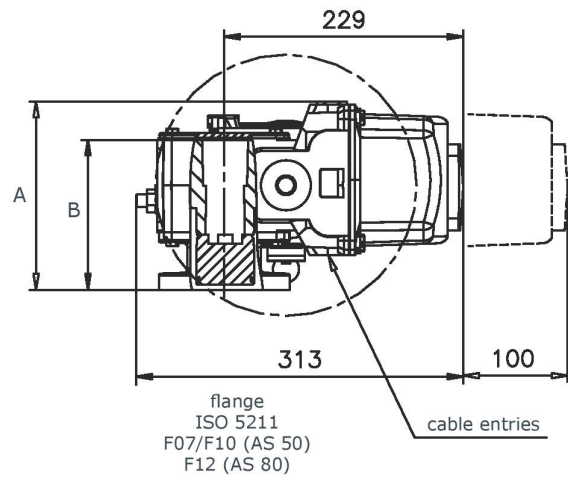
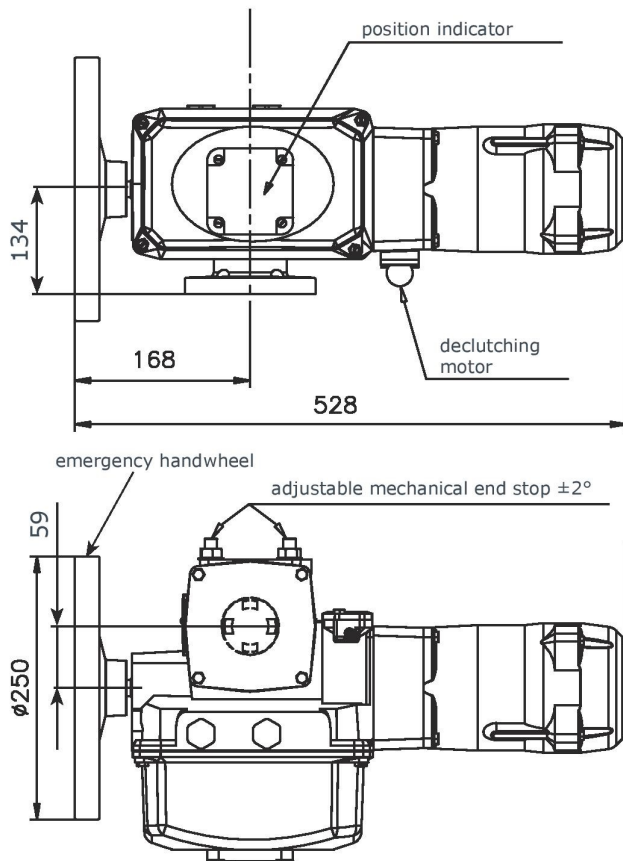

mod.	A	B	Kg
AS 50	180	144	20
AS 80	211	175	21

AS 100 - AS 200 - AS 400 - AS 600 - AS 1000 Type

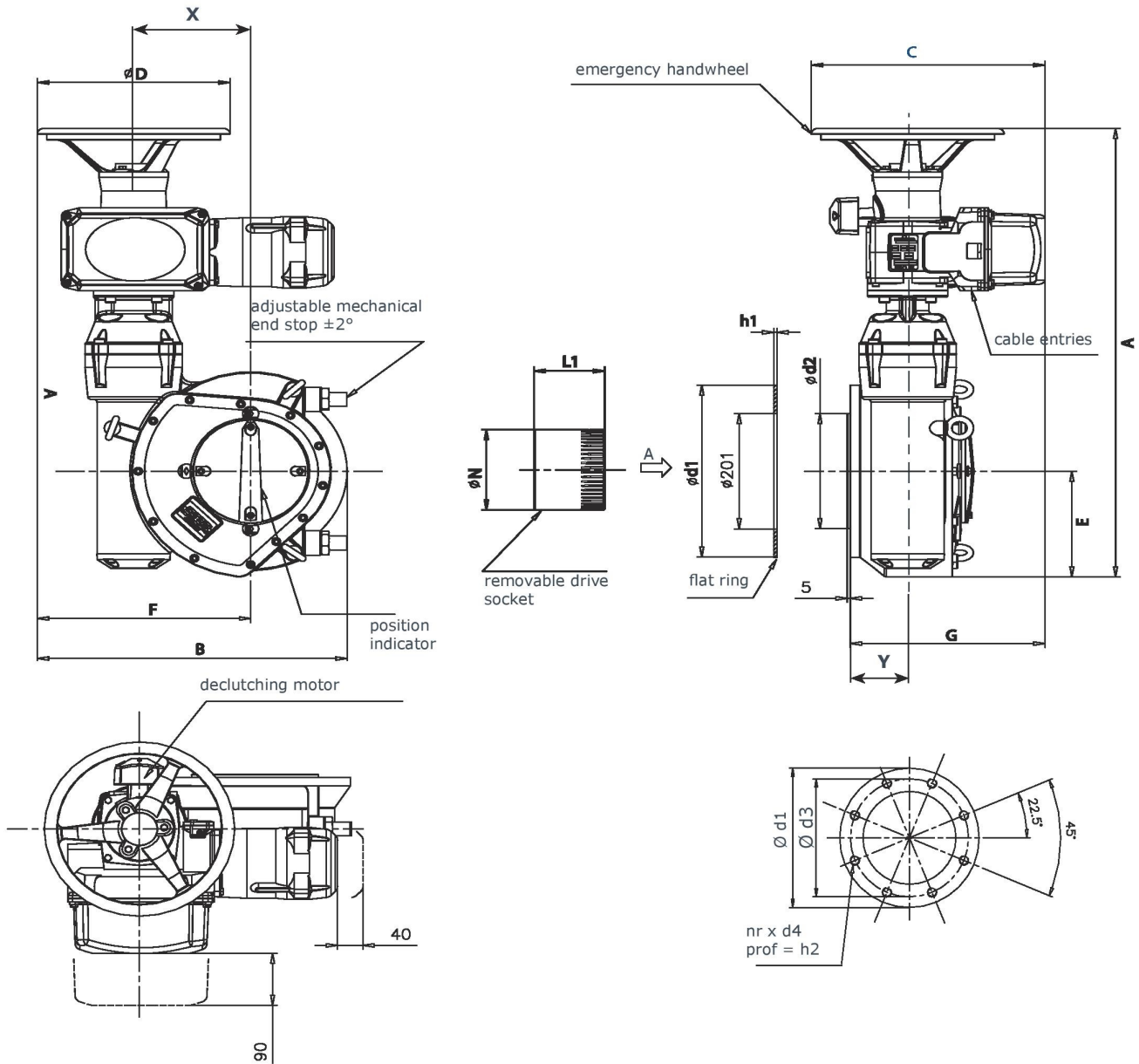

Mod.	A	B	C	φD	E	F	L1	φN	P	X	Y	Kg.	ISO	G	φd1	φd2	φd3	nr	d4	h1	h2
AS100	521	425	364	300	114	199	64	86	32	86	71	40	F10	283	150	-	102	4	M10	-	21
													F12	262	150	85f8	125	8	M12	3	18
													F14	283	175	100f8	140	4	M16	4	21
AS200	664	462	364	300	188	333	103	110	48	183	71	57	F14	284	210	-	140	4	M16	-	30
													F16	284	210	130f8	165	4	M20	5	30
AS400	664	462	364	300	154	288	103	110	40	138	71	60	F16	284	210	130f8	165	4	M20	5	30
AS600	742	532	414	400	184	382	110	140	54	182	89	84	F25	303	300	200f8	254	8	M16	5	24
AS1000	780	482	364	300	184	332	110	140	54	182	89	85	F25	303	300	200f8	254	8	M16	5	24

Electric actuators **NA****NA Series - quarter turn: 50 Nm - 2500 Nm**

Our new quarter-turn electric actuator "NA series" is designed to operate butterfly and ball valves. Strong and solid construction (body in die-cast aluminium IP68/67); standard construction with 2 additional switches, heater resistance, visual position indicator usually from stock.

Range also includes accessories such as CPU (Proportional Control Unit 4-20 mA) or LCU (Local Control Unit)

Atex version also possible on request.



Standard features:

- Aluminium body, polyester coating
- Working temperature: -20°C / +70°C
- Flange: ISO5211
- Power supply: 24V CC/AC, 230V AC, 400V Trifase
- Protection: IP67 NEMA 4 - 6
- Torque moment: 60 Nm / 3.000 Nm
- Limit switches: 2 (OPEN/CLOSE) torque switches (from NA15), thermal protection, 2 electric travel limit switches.
- Travel angle: 90° +/- 5°
- Space heater: 20W (NA06 / NA250)
- Duty cycle: 50% / 25%
- Handwheel manual override

Optionals:

EXP	Explosion Proof & Watertight Enclosure Ex d B T4 IP 67, EEx d B T4 (NEMKO)
DCM	24 V DC Motor
ALS	Additional Auxiliary Limit Switches
EXT	Travel Angle 120°, 135°, 180°, 270°, 300°
LCU	Local Control Unit Local / Remote Selector Switch Open / Stop / Close Selector Switch or Push button type
PIU	Potentiometer Unit 1K Ohm.
CPT	Current Position Transmitter Output : DC 4-20mA
PCU	Proportional Control Unit Power : AC 110/220V 1PH, DC 24V Input : DC 4-20mA, DC 1-5 V, DC 2-10 V Output : DC 4-20 mA
IMS	Integral Motor Starter Reversing Magnet Contacts and Transformer

type	torque [Nm]	operating time 50Hz (sec)	protection	SA%	power W	Ø max stem	rated current - A				Flange ISO 5211	num hand-wheels turn	Kg
							single phase 50Hz 110V	220 V	3 phase 50Hz 380 V	24 V DC			
NA 06	60	17	IP67	50	15	22	0.75	0.45	0.13	2.2	F07	8,5	11
NA 09	90	17	IP67	50	25	22	1.2	0.58	0.18	3.5	F07	8,5	11
NA 15	150	20	IP67	50	40	22	1.6	0.95	0.3	4.5	F07/10	10	12
NA 19	190	20	IP67	50	40	22	1.6	0.95	0.3	5	F07/10	10	13
NA 28	280	24	IP67	50	40	32	1.8	0.95	0.3	6.5	F10/12	12,5	17
NA 38	380	24	IP67	30	60	32	2.3	1.3	0.33	≈	F10/12	12,5	18
NA 50	500	24	IP67	25	90	32	3.9	1.5	0.52	≈	F10/12	12,5	19
NA 60	600	29	IP67	25	90	42	3.9	1.5	0.52	≈	F12/14	14,5	22
NA 80	800	29	IP67	25	180	42	4.7	2.15	0.73	≈	F12/14	14,5	23
NA 100	1000	29	IP67	25	180	42	4.7	2.15	0.73	≈	F12/14	14,5	25
NA 150	1500	87	IP67	25	90	75	3.9	1.5	0.52	≈	F12/F14 F16	43,5	68
NA 200	2000	87	IP67	25	180	75	4.7	2.15	0.73	≈	F12/F14 F16	43,5	70
NA 250	2500	87	IP67	25	180	75	4.7	2.15	0.73	≈	F12/F14 F16	43,5	70
NA 300	3000	116	IP67	25	180	75	4.7	2.15	0.73	≈	F12/F14 F16	58	72

Hydraulic actuators - **ARES** type

Features:

- Compact design
- 90° rotation $\pm 5^\circ$
- Travel adjustment in both direction of rotation
- Flange ISO 5211
- Double or single acting with spring return

Accessories

- Manual emergency control with decluchable override or hydraulic pump
- Limit switch boxes available with a wide range of switches and position transmitters
- Hydraulic circuits with solenoid valves, electro-hydraulic supply system, accumulator, etc..., for valve operation and control.

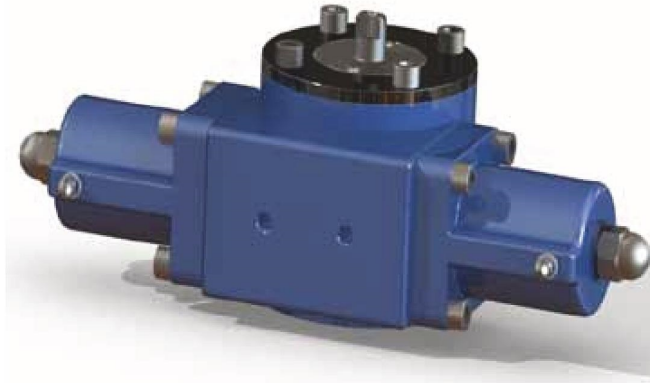

ARES - DA type - double acting

- Technical features:
 - » ductile iron cast body
 - » steel rack and pinion
 - » NBR seats
- fluid material:
 - » hydraulic oil type : HPL DIN51524-2 / ISO 6743-4. Viscosity 15/200 cst
- working pressure: 10 - 120 bar
- working temperature: -20°C / +80°C

No routine maintenance or lubrication is required.
All movings parts are lubricated with heavy duty grease.

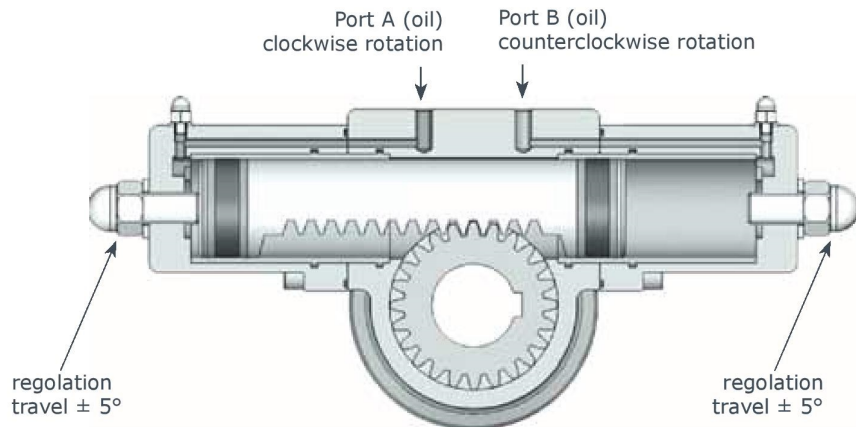

Torque hydraulic actuators double acting DA - Nm

TIPO/TYPE	10 Bar	20 Bar	30 Bar	40 Bar	50 Bar	60 Bar	70 Bar	80 Bar	90 Bar	100 Bar	110 Bar	120 Bar
ARES 28DA	19	38	57	74	93	112	129	148	167	185	203	221
ARES 40DA	40	80	110	150	190	230	260	300	340	380	410	450
ARES 50DA	80	150	230	310	380	460	530	610	690	760	840	920
ARES 63DA	150	300	460	610	760	910	1070	1220	1370	1520	1680	1830
ARES 80DA	260	530	790	1050	1320	1580	1840	2100	2370	2630	2890	3160

ARES - SR type - single acting

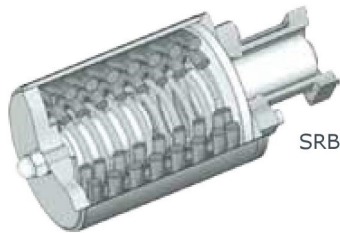
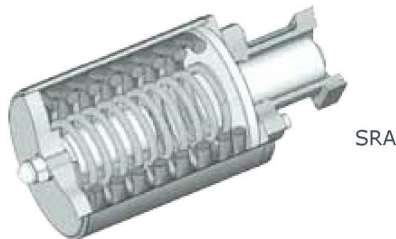
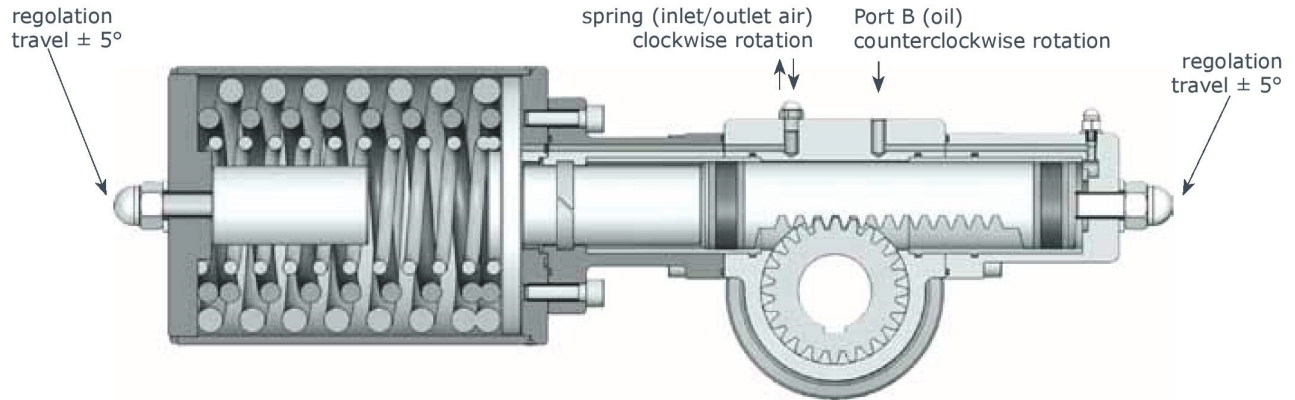

Single acting ARES actuators with spring return can be equipped with two different types of spring cartridges depending upon the torque required:

- » SRA with reduced thrust
- » SRB with the maximum thrust

The spring cartridge torque values are indicated in following tables.

Remarks: dimensioning the actuator please carefully select the spring cartridge because if it is necessary to modify the torque it is not possible to remove or add springs but it is necessary to substitute the complete cartridge.

Torque hydraulic actuators single acting SRA / SRB - Nm

type	spring cartridge	springs torque Nm		40 Bar		60 Bar		90 Bar		120 Bar	
		0°	90°	0°	90°	0°	90°	0°	90°	0°	90°
ARES 40SR	SRA	81	121	67	28	144	104	255	216	≈	≈
	SRB	162	242	≈	≈	≈	≈	175	96	288	208
ARES 50SR	SRA	164	243	143	64	294	215	523	443	--	--
	SRB	328	486	≈	≈	≈	≈	360	201	588	430
ARES 63SR	SRA	328	493	280	115	585	420	1035	873	≈	≈
	SRB	656	986	≈	≈	≈	≈	710	381	1170	840
ARES 80SR	SRA	560	840	486	207	1010	730	1804	1524	≈	≈
	SRB	1120	1680	≈	≈	≈	≈	1245	686	2020	1460

Hydraulic actuators - ARES type

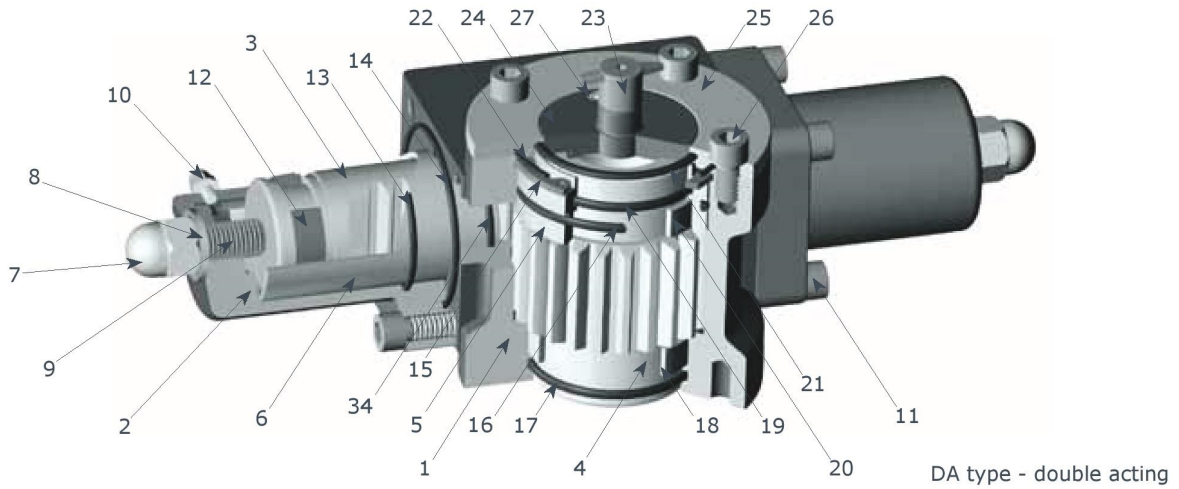

item	part	material	coating	q.ty DA	q.ty SR	item	part	material	coating	q.ty DA	q.ty SR
1	Body	Ductile iron	Epoxi coated	1	1	18	Lower pinion guide band	Reinforced POM	--	1	1
2	End cap	Ductile iron	Epoxi coated	2	1	19	O Ring	NBR	--	1	1
3	Piston rack	Steel	--	1	1	20	Upper pinion guide band	Reinforced POM	--	1	1
4	Pinion	Steel	--	1	1	21	O Ring	NBR	--	1	1
5	Pinion cap	Steel	--	1	1	22	O Ring	NBR	--	1	1
6	Cylinder	Steel	Lapped	2	2	23	Position indicator	Polyamide	--	1	1
7	Adjustment nut	Stainless steel	--	2	2	24	Position indicator flange	Aluminium	Anodized	1	1
8	Bleed nut	Steel + NBR	--	2	2	25	Upper flange	Aluminium	Anodized	1	1
9	Adjustment screw	Steel	--	2	1	26	Flange screw	Steel	--	4	4
10	Bleed screw	Steel	--	2	1	27	Flange screw	Steel	--	2	2
11	Endcap screw	Steel	--	8	8	28	Springs cartridge	Steel	Epoxi coated	--	1
12	Piston seal	Reinforced POM+NBR	--	2	2	29	Piston extension	Steel	Chromium plated	--	1
13	O Ring	NBR	--	4	3	30	O Ring	NBR	--	--	1
14	O Ring	NBR	--	2	2	31	Extension guide band	Reinforced POM	--	--	1
15	Snap ring	Steel	--	1	1	32	Springs cartridge bracket	Ductile iron	Epoxi coated	--	1
16	O Ring	NBR	--	1	1	33	Screw	Stee	--	--	4
17	O Ring	NBR	--	1	1	34	O-ring	NBR	--	--	2

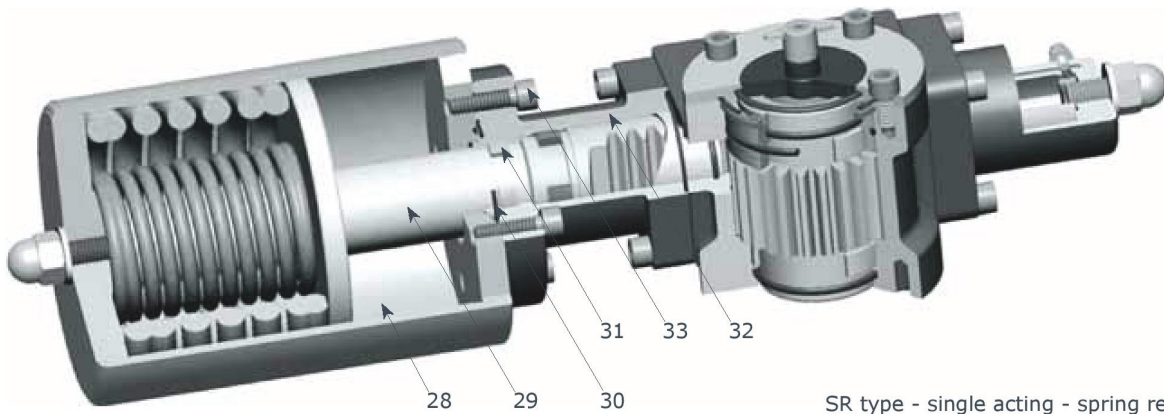

Hydraulic actuators - ARES type

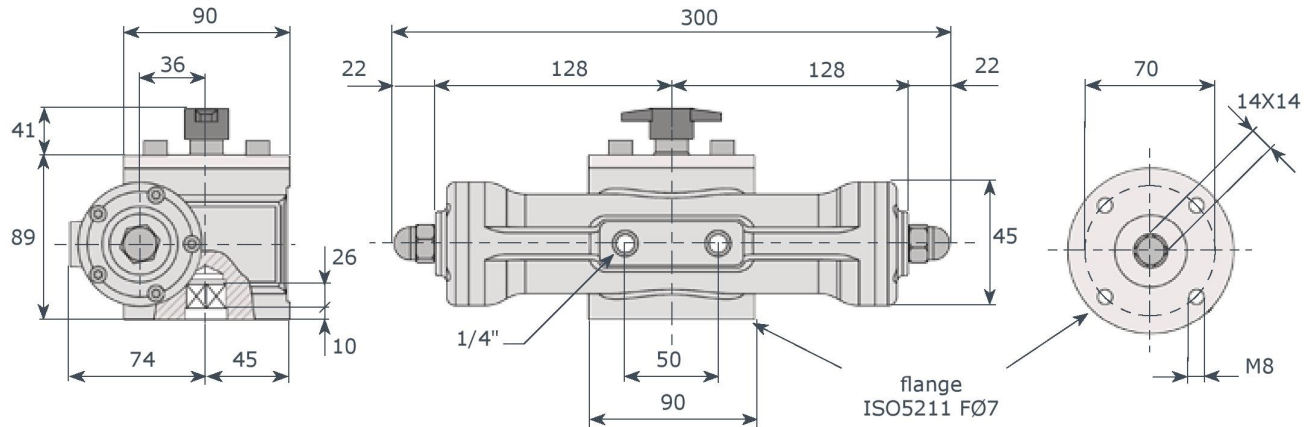

ARES H 28 - DA weight 8,5 Kg - volume 32 cmc

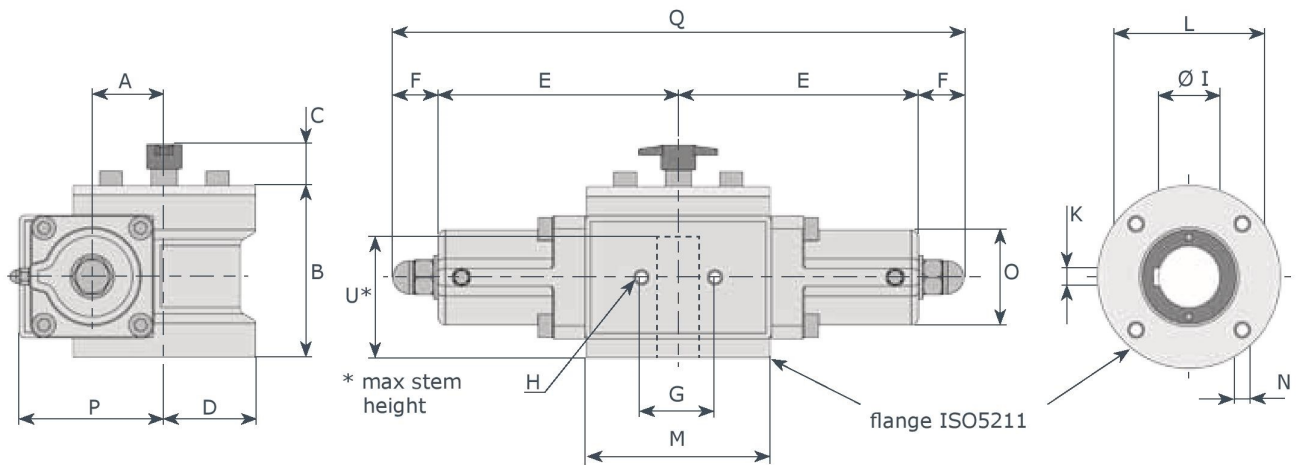

ARES H 40 / H 50 / H 63 / H 80 DA

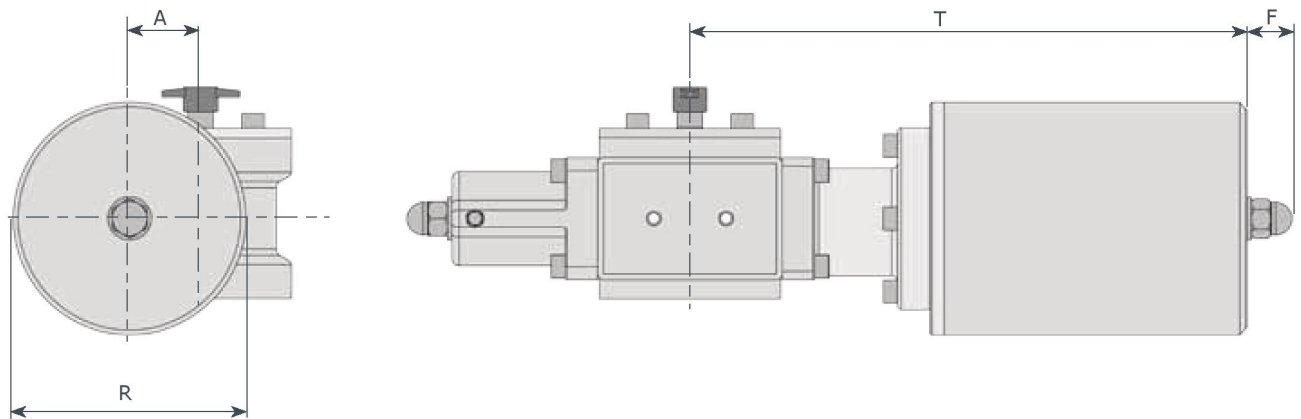

ARES H 40 / H 50 / H 63 / H 80 SR

mod	ISO 5211	A	B	C	D	E	F	G	H	Ø I	K	L	M	N	O	P	Q	R	T	U*	DA Kg	SR Kg	vol. cm ³
H 40	F07	40	102	41	45	143	30	50	1/4"	28	8	70	90	M8	55	85	346	140	325	91	12	29	59
H 50	F10	50	117	41	62.5	164	30	50	3/8"	42	12	102	125	M10	66	100	387	160	390	106	19	45	120
H 63	F12	63	127	41	75	201	40	50	3/8"	50	14	125	150	M12	80	125	482	210	545	116	30	75	239
H 80	F14	80	157	41	87.5	225	45	50	3/8"	60	18	140	175	M16	106	163	540	240	575	146	52	120	414

