



PTFE SEATED
BUTTERFLY VALVES



G **PTFE SEATED BUTTERFLY VALVES**

BVTT - WAFER
DN 50-500 • 2"-20"

BLTT - LUG
DN 65-200 • 3"-12"



The valve discs are available in stainless steel with PTFE coating, HALAR® coating or stainless steel (AISI316, DUPLEX®, SUPERDUPLEX®, HASTELLOY®, INCONEL®, etc.). Standard shafts are in AISI316, (on request Monel® or other materials)



The thickness of the PTFE body seat varies from 2,5 to 3 mm depending on the position



Two sets of Belleville washer guarantee the sealing between the disc and the PTFE seat. A double packing consisting in a FKM O-Ring FEP coated and a PTFE c-ring, avoids any leakage along the valve shaft

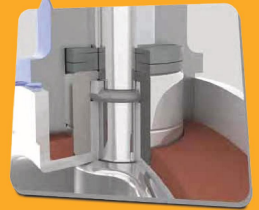

Two silicone half rings increase and ensure the flexibility of the PTFE seat up to the maximum working temperatures

On the TT valve series, the PTFE disc coating covers the shaft until after the seal on the shaft, so that the fluid can never come in contact with the materials

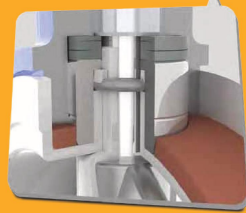

PTFE seat



PTFE SEATED

TT Series

	1
• technical data	1
• components DN 50-300	2
Stainless steel disc	2
Stainless steel + PTFE disc	3



tables

• components DN 350-500	4
• dimensions	5
• torque values	6

Installation instructions	7
Tests	7
Handlever	9
Gearbox	10

Butterfly valves

PTFE seat

BVTT - Wafer
DN 50 - 500 • 2" - 20"

BLTT - Lug
DN 50 - 300 • 2" - 12"

Max working pressure:

BVTT/BLTT DN 50÷400: **10 Bar**
Flange: **PN 10-16-A150**

BVTT DN 500: **6 Bar**
Flange: **PN 10-16-A150**

To be used for vacuum (not with PTFE disc)

Design:

EN 593 ~ EN 736 ~ EN 12516 ~ EN 1092
ISO 5211 ~ DIN 3337 ~ API 609
PED 97/23/EC (cat III) Mod H

Face to face:

DIN EN 558-1 Series 20 ~ ISO 5752 Series 20
BS-5155 Series 4 ~ MSS-SP67
API 609 cat. A ~ NFE 29305-1

Testing:

EN 12266-1 Rate A ~ ISO 5208 Rate A
DIN 3230 ~ API 598

Tag:

EN 19 ~ MSS SP-25



Alle the valves are supplied with a metallic label in compliance with PED directive.

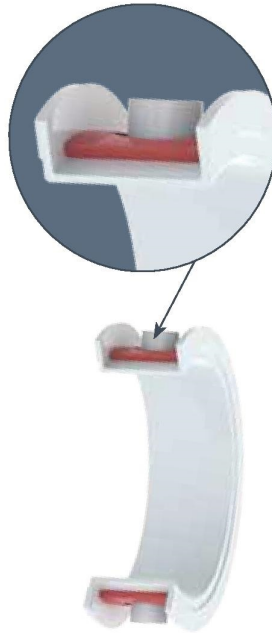

The thickness of the PTFE body seat varies from 2,5 to 3 mm depending on the position



Epoxy
EPOXY
COATED



BODY

material	references	standard coating	lug	wafer
Ductile iron (wafer, lug)	EN-GJS 400-15 (GS400)	Epoxy RAL 5009	50-300	50-500
Carbon steel (wafer)	ASTM A216-WCB	Epoxy RAL 9005	-	50-500
Stainless steel (wafer)	ASTM A351 CF8M (A316)	-	-	50-500

DISC

material	references	standard coating	coating on request	DN
Stainless steel	ASTM A351 CF8M (A316)	-	HALAR®	50-500
Stainless steel	ASTM A564 Type 630	PTFE	-	50-300
Hastelloy®	ASTM A494 CX2MW	-	-	50-500
Monel®	ASTM A494 M35-1	-	-	50-500

BODY SEAT

ref.	designation	trade name	working temp.	applications
PTFE	polytetrafluorethylene	TEFLON®	-60°C / +190°C	acids, foods, solvents

On request can be supplied other materials as: LCB, Hastelloy, Monel, Uranus, Alloy, DUPLEX, Special steels, Special bronzes.
Coating on request: RILSAN®, Halar®, Chenisil®

BVTT - Wafer BLTT - Lug
 DN 50 - 300 • 2" - 12"
 PN 10-16 • ANSI 150

Stainless steel (ASTM A351 CF8M) disc

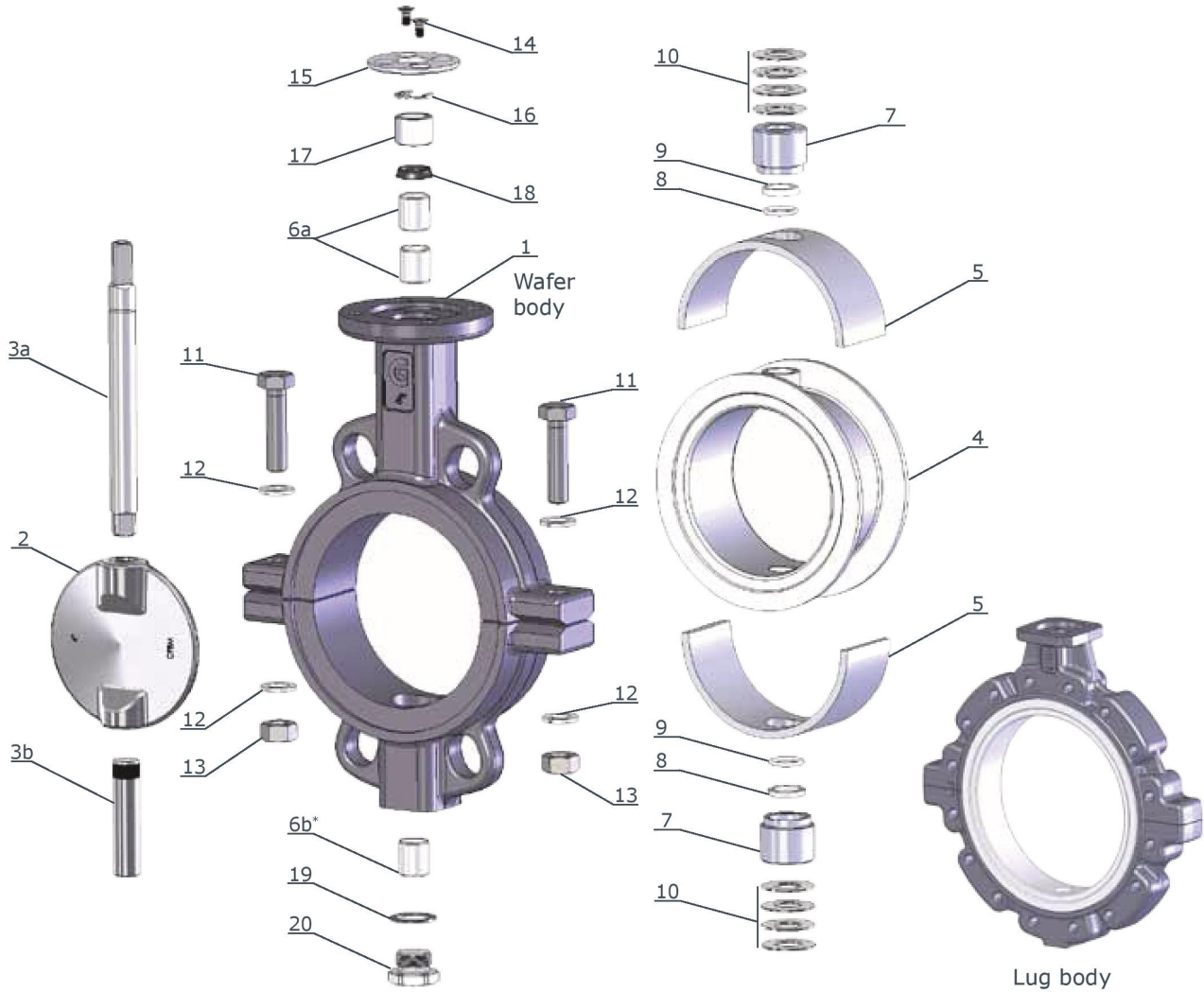

item	q.ty	part	material	item	q.ty	part	material
1	1	body	<ul style="list-style-type: none"> ductile iron GS400 A216 - WCB A351 - CF8M (AISI 316) 	11	2	screw	<ul style="list-style-type: none"> zinc plated steel AISI 316 (body AISI 316)
2	1	disc	<ul style="list-style-type: none"> A351 - CF8M (AISI 316) HALAR® (on request) 	12	4	washer	<ul style="list-style-type: none"> zinc plated steel AISI 316 (body AISI 316)
3a	1	upper shaft	<ul style="list-style-type: none"> AISI 316 	13	2	screw nut	<ul style="list-style-type: none"> zinc plated steel AISI 316 (body AISI 316)
3b	1	lower shaft	<ul style="list-style-type: none"> AISI 316 	14	2	screw	<ul style="list-style-type: none"> zinc plated steel AISI 316 (body AISI 316)
◇4	1	body seat	<ul style="list-style-type: none"> PTFE 	15	1	upper flange	<ul style="list-style-type: none"> IXEF (DN 50/150) aluminium (DN 200/300)
◇5	1	elastic support	<ul style="list-style-type: none"> silicon 	16	1	stop ring	<ul style="list-style-type: none"> steel
6a	2	bush upper shaft	<ul style="list-style-type: none"> steel + PTFE 	◇17	1	upper bush	<ul style="list-style-type: none"> PFTE
6b*	1*	bush lower shaft	<ul style="list-style-type: none"> steel + PTFE 	◇18	1	O.Ring	<ul style="list-style-type: none"> FKM (VITON®)
7	2	housing	<ul style="list-style-type: none"> AISI 316 	19	1	plug paking	<ul style="list-style-type: none"> aluminium PTFE (body AISI 316)
◇8	2	O. Ring	<ul style="list-style-type: none"> FEP + FKM (VITON®) 	20	1	threaded plug	<ul style="list-style-type: none"> zinc plated steel AISI 316 (body AISI 316)
◇9	2	C. Ring	<ul style="list-style-type: none"> PTFE 				
10	2	springs set	<ul style="list-style-type: none"> steel 				

* only DN200/300

◇ parts included in spare kit

BVTT - Wafer BLTT - Lug
 DN 50 - 300 • 2" - 12"
 PN 10-16 • ANSI 150

Stainless steel disc (ASTM A564 Type 630) PTFE coated

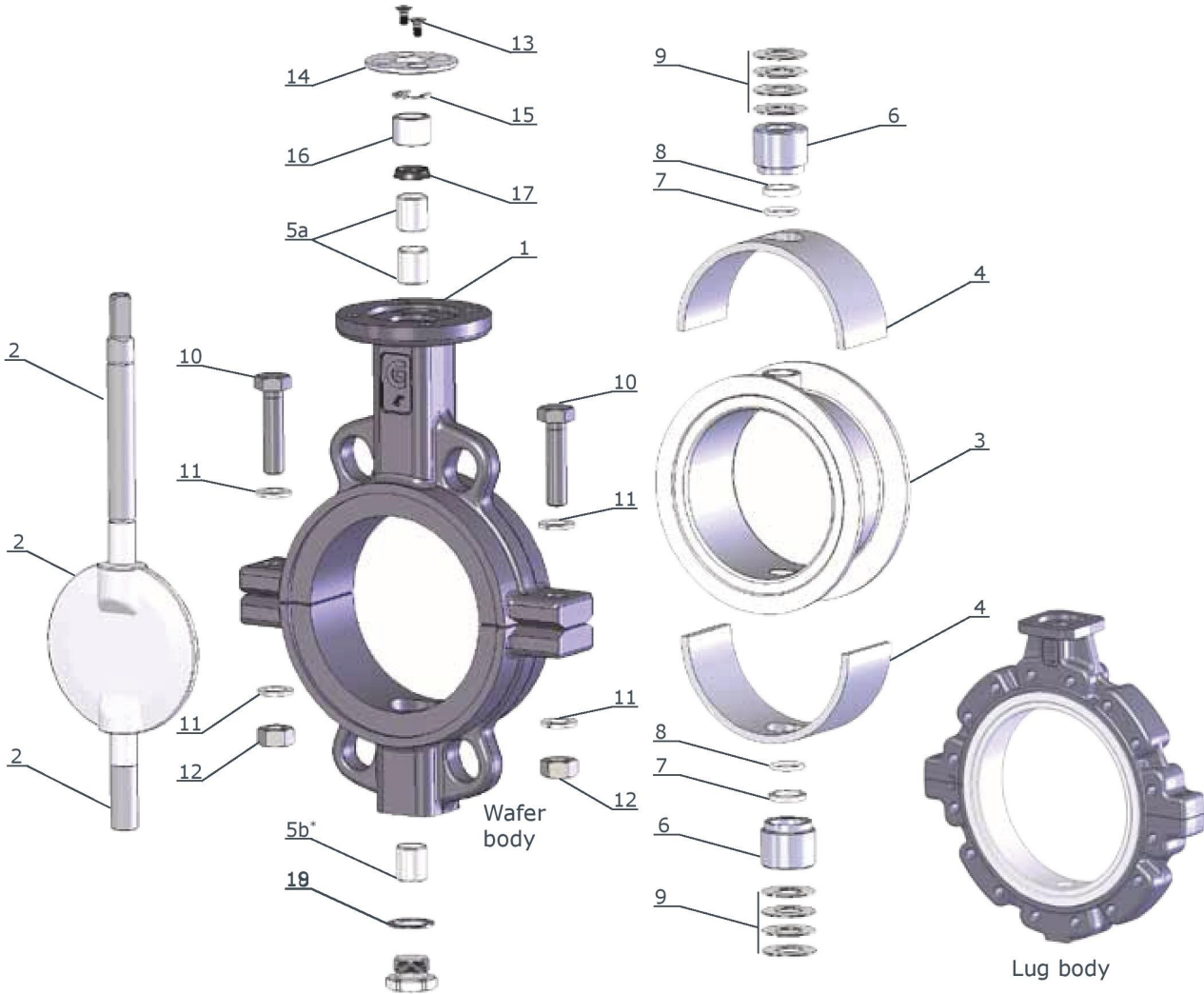

item	q.ty	part	material	item	q.ty	part	material
1	1	body	<ul style="list-style-type: none"> ductile iron GS400 A216 - WCB A351 - CF8M (AISI 316) 	11	4	washer	<ul style="list-style-type: none"> zinc plated steel AISI 316 (body AISI 316)
◇2	1	disc - shafts	<ul style="list-style-type: none"> ASTM A564 Type 630 + PTFE 	12	2	screw nut	<ul style="list-style-type: none"> zinc plated steel AISI 316 (body AISI 316)
◇3	1	body seat	<ul style="list-style-type: none"> PTFE 	13	2	screw	<ul style="list-style-type: none"> zinc plated steel AISI 316 (body AISI 316)
◇4	1	elastic support	<ul style="list-style-type: none"> silicon 	14	1	upper flange	<ul style="list-style-type: none"> IXEF (DN 50/150) aluminium (DN 200/300)
5a	2	bush upper shaft	<ul style="list-style-type: none"> steel + PTFE 	15	1	stop ring	<ul style="list-style-type: none"> steel
5b*	1*	bush lower shaft	<ul style="list-style-type: none"> steel + PTFE 	◇16	1	upper bush	<ul style="list-style-type: none"> PFTE
6	2	housing	<ul style="list-style-type: none"> AISI 316 	◇17	1	O.Ring	<ul style="list-style-type: none"> FKM (VITON®)
◇7	2	O. Ring	<ul style="list-style-type: none"> FEP + FKM (VITON®) 	18	1	plug paking	<ul style="list-style-type: none"> aluminium PTFE (body AISI 316)
◇8	2	C. Ring	<ul style="list-style-type: none"> PTFE 	19	1	threaded plug	<ul style="list-style-type: none"> zinc plated steel AISI 316 (body AISI 316)
9	2	springs set	<ul style="list-style-type: none"> steel 				
10	2	screw	<ul style="list-style-type: none"> zinc plated steel AISI 316 (body AISI 316) 				

* only DN200/300

◇ parts included in spare kit

BVTT - Wafer

DN 350 - 500 • 14" - 20"

PN 10-16 • ANSI 150

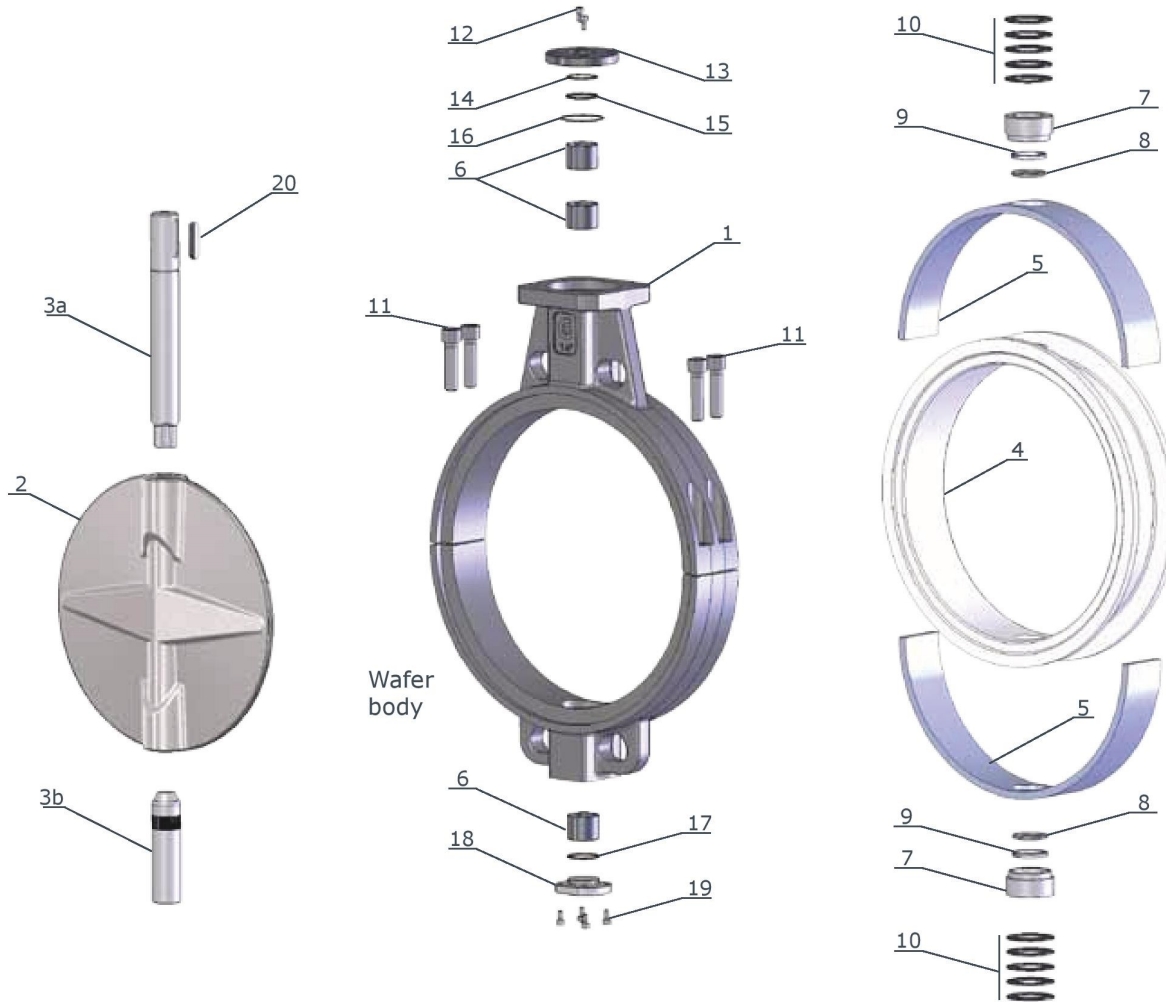

item	q.ty	part	material	item	q.ty	part	material
1	1	body	<ul style="list-style-type: none"> ductile iron GS400 A216 - WCB A351 - CF8M (AISI 316) 	11	4	screw	<ul style="list-style-type: none"> zinc plated steel AISI 316 (body AISI 316)
2	1	body	<ul style="list-style-type: none"> A351 - CF8M (AISI 316) HALAR® (on request) 	12	2	screw	<ul style="list-style-type: none"> zinc plated steel AISI 316 (body AISI 316)
3a	1	upper shafts	<ul style="list-style-type: none"> AISI 316 	13	1	upper flange	<ul style="list-style-type: none"> zinc plated steel AISI 316 (body AISI 316)
3b	1	lower shafts	<ul style="list-style-type: none"> AISI 316 	◇14	1	O.Ring	<ul style="list-style-type: none"> FKM (VITON®)
◇4	1	body seat	<ul style="list-style-type: none"> PTFE 	15	1	stop ring	<ul style="list-style-type: none"> steel
◇5	1	elastic support	<ul style="list-style-type: none"> silicon 	◇16	1	O.Ring	<ul style="list-style-type: none"> FKM (VITON®)
6	3	bush shaft	<ul style="list-style-type: none"> A105 + PTFE 	◇17	1	O.Ring	<ul style="list-style-type: none"> FKM (VITON®)
7	2	housing	<ul style="list-style-type: none"> AISI 316 	18	1	lower flange	<ul style="list-style-type: none"> zinc plated steel AISI 316 (body AISI 316)
◇8	2	O. Ring	<ul style="list-style-type: none"> FEP + FKM (VITON®) 	19	4	screw	<ul style="list-style-type: none"> zinc plated steel AISI 316 (body AISI 316)
◇9	2	C. Ring	<ul style="list-style-type: none"> PTFE 	20	1	key	<ul style="list-style-type: none"> steel C40
10	2	springs set	<ul style="list-style-type: none"> steel 				

◇ parts included in spare kit

BVTT - Wafer BLTT - Lug

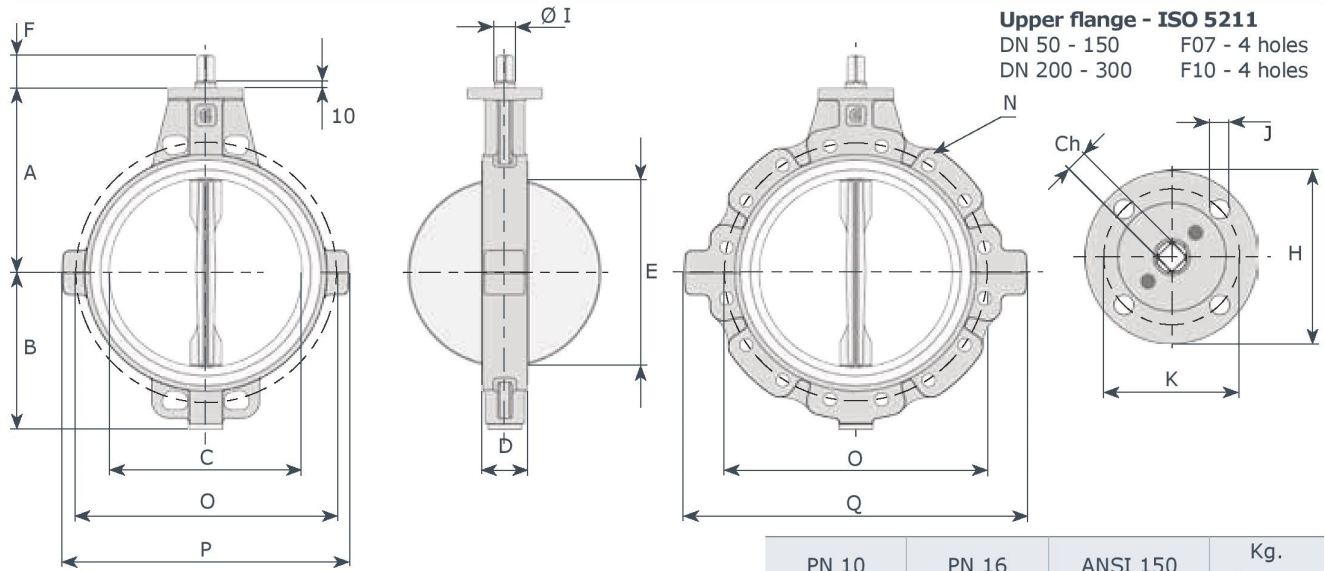

DN	"	A	B	C	D	E	F	Ø I	Ch	H	K	J	P	Q	PN 10			PN 16			ANSI 150			Kg.	
															N	n.	O	N	n.	O	N	n.	O	wafer	lug
50	2	138	81	55	43	35	34	14	11	90	70	9	165	165	M16	4	125	M16	4	125	M16	4	120.6	3.4	3.9
65	2½	144	98	68	46	50	34	14	11	90	70	9	186	186	M16	8	145	M16	8	145	M16	4	139.7	4.1	4.7
80	3	158	110	81	46	67	34	14	11	90	70	9	196	242	M16	8	160	M16	8	160	M16	4	152.4	4.4	7.6
100	4	173	128	101	52	87	34	16	11	90	70	9	220	270	M16	8	180	M16	8	180	M16	8	190.5	6.8	8.4
125	5	186	140	126	56	113	34	18	14	90	70	9	250	297	M16	8	210	M16	8	210	M20	8	215.9	8.8	11.2
150	6	202	155	150	56	140	34	18	14	90	70	9	278	321	M20	8	240	M20	8	240	M20	8	241.3	10.5	12.9
200	8	240	190	200	60	191	38	22	17	125	102	11	355	420	M20	8	295	M20	12	295	M20	8	298.4	15.2	25.0
250	10	270	220	250	68	241	38	30	22	125	102	11	398	472	M20	12	350	M24	12	355	M22	12	361.9	24.5	30.0
300	12	300	247	298	78	289	38	30	22	125	102	11	455	540	M20	12	400	M24	12	410	M22	12	431.8	32.0	45.0

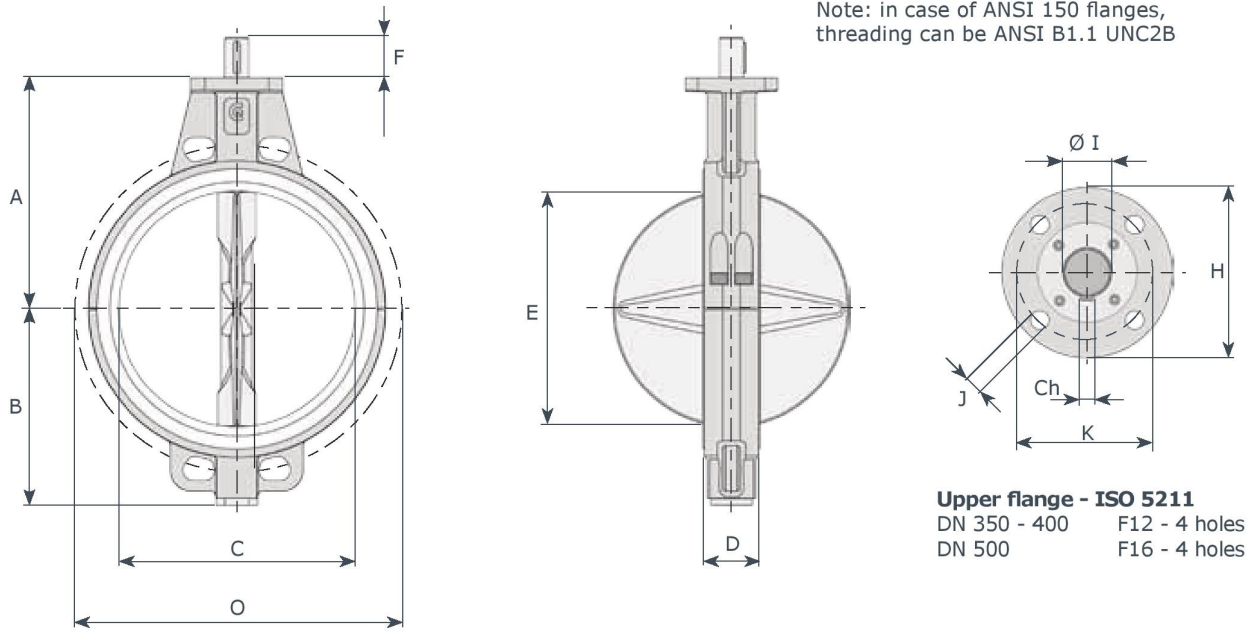

DN	"	A	B	C	D	E	F	Ø I	Ch	H	K	J	Kg.
350	14	330	280	341	78	332	60	35	10	150	125	14	54
400	16	355	305	390	102	376	60	40	12	150	125	14	68
500	20	422	366	495	127	479	60	45	12	210	165	22	149

TT Series - Torque values - Nm - safety factor excluded

disc: CF8M (A316)				fluid H ₂ O - 20°C working pressure BAR				disc: A564 (A630) + PTFE				fluid H ₂ O - 20°C working pressure BAR			
DN	0	6	10	DN	0	6	10	DN	0	6	10	DN	0	6	10
50	13	16	19	125	45	57	75	300	214	296	366	50	12	15	18
65	15	21	24	150	53	63	94	350	400	550	-	65	14	20	23
80	28	42	52	200	128	153	188	400	700	995	-	80	26	40	49
100	32	54	65	250	198	232	296	500	980	1250	-	100	30	51	62
												200	122	145	180
												250	180	220	280
												300	311	344	385

Head losses

notes: values indicated in this page is only for information

Formulae for calculation of rate flow

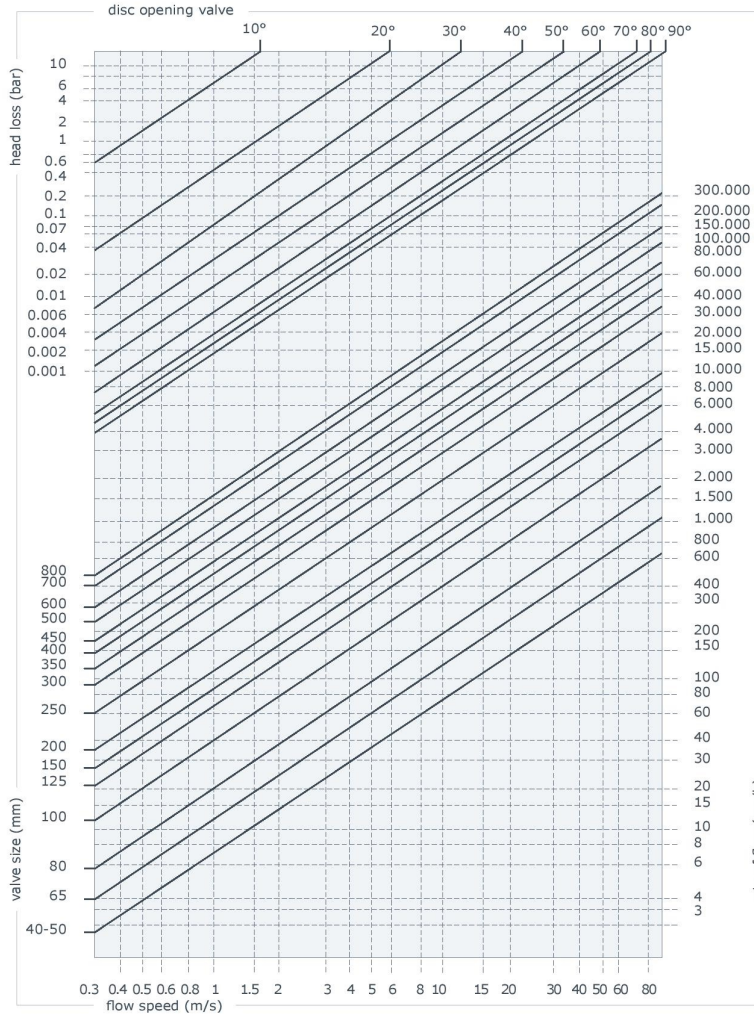

Liquids:
$$Q = \frac{KV}{\sqrt{\frac{PS}{\Delta P}}}$$

Q rate of flow (m³/h)
PS specific gravity (water=1)
ΔP pressure drop (bar)

Gas:
$$Q = 28.5 \frac{KV}{\sqrt{P_2 \cdot \Delta P}}$$

Q rate of flow (m³/h)
PS specific gravity (air=1)
ΔP pressure drop (bar)
(less than 1/2 inlet pressure)
P₂ outlet pressure

Steam:
$$Q = 22.5 \cdot KV \cdot \sqrt{P_2 \cdot \Delta P}$$

Q rate of flow (Kg/h)
ΔP pressure drop (bar)
(less than 1/2 inlet pressure)
P₂ outlet pressure

Calculation of the rate of flow equivalent to H₂O:

$$Q_e = Q \sqrt{\frac{d}{1000}}$$

For different liquid, gas or steam head losses are determined by equivalent water rate of flow, as follows:

Q_e equivalent water flow (mc/l o l/s)
Q fluid flow (mc/l o l/s)
d fluid specific gravity (Kg/mc)

Values KV (CV = 1,16 KV)

angle	40/50	65	80	100	125	150	200	250	300	350	400	500
5°	-	-	-	-	-	-	-	-	-	53	68	106
10°	-	-	-	-	-	-	-	21	49	123	161	246
15°	0,2	0,6	1,8	2,4	4,2	5,6	14	80	188	228	299	457
20°	0,9	2,5	5,2	9,5	15	23	110	156	280	315	412	630
25°	3	6,1	12	22	38	61	125	225	354	457	597	914
30°	6,1	11	21	39	69	112	211	310	381	661	863	1320
35°	9,9	18	33	60	105	166	303	433	521	890	1162	1778
40°	15	27	49	88	148	228	405	591	742	1184	1547	2366
45°	21	38	68	121	199	303	528	774	987	1552	2028	3102
50°	29	51	91	159	262	394	679	988	1252	2008	2620	4010
55°	39	68	119	207	338	505	863	1247	1571	2548	3318	5090
60°	53	90	156	269	434	641	1085	1591	2059	3225	4202	6442
65°	72	121	209	357	565	820	1364	2065	2807	3983	5196	7957
70°	92	161	283	487	768	1097	1788	2715	3744	5195	6775	10377
75°	109	209	381	662	1059	1507	2425	3625	4935	6964	9084	13912
80°	115	240	457	815	1303	1861	3043	4768	6831	9301	12142	18578
85°	115	253	502	906	1457	2008	3642	4890	8230	10280	13408	20533
90°	116	257	508	925	1492	2168	3838	5010	9233	10792	14082	22024

Installation and test

Assembly

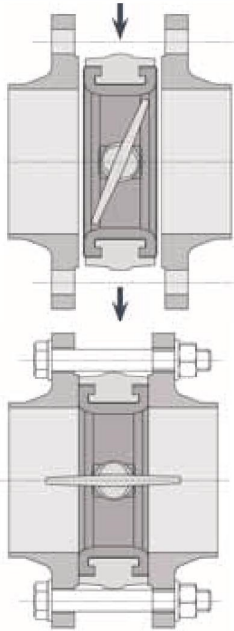

1 - Leave a space between flanges so that valve can be easily inserted and removed.

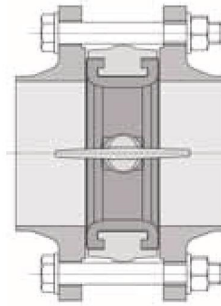

2 - Open completely the valve before tightening flanges.

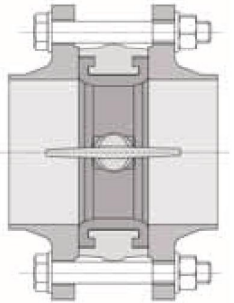

3 - Tighten bolts till flanges are in contact with valve body.

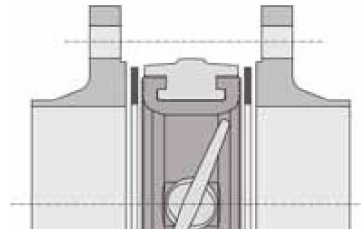

4 - NOTE: do not insert other packing between flange and valve.

NOTE: Weld the pipe only in spots with the valve between flanges. Remove the valve before finishing welding to avoid that heat damage the seat. Clean carefully the welding to avoid that slags damage the seat.

Installation for powders and muddy fluids

In case of use with muddy fluids or powders, install the valve with horizontal rotation axis, to allow sediments to flow easily on opening.

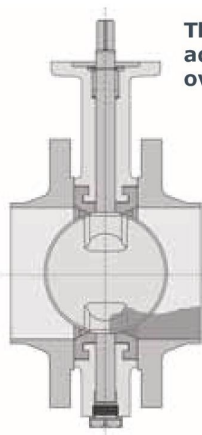

Wrong
Vertical rotation axis

This type of installation is always advisable with valve diameters over DN 400.

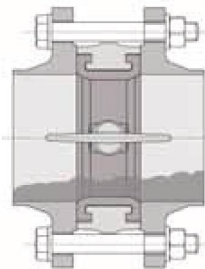

Right
Horizontal rotation axis

End piping installation

When valves are installed end of piping, a counterflange as per dwg type B is needed to secure tightness at max pressure.

Type A installation without end piping

$P_{max} = 4 \text{ bar}$

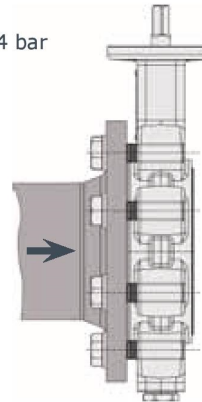

Type B installation with end piping

$P_{max} = 10 \text{ bar}$

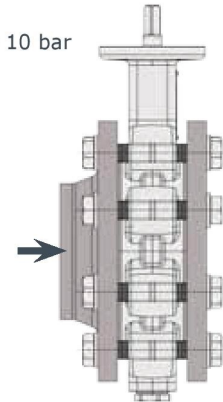

Test

valves are built according to following international standards:

Body test pressure:	DIN 3230BA - API598
Hydraulic test pressure:	DIN 3230BN1 - API598
Pneumatic test pressure:	DIN 3230BO1 - API598
Test certificates:	UNI EN 10204 2.2 (standard)
	UNI EN 10204 3.1 (on request)
	UNI EN 10204 3.2 (on request)

Test duration is indicated by API598 standard

Body test pressure:	Hydraulic test pressure:	Pneumatic test pressure:
< DN 65 = 15 sec.	< DN 65 = 15 sec.	< DN 65 = 15 sec.
DN 65 / DN 200 = 80 sec.	DN 65 / DN 200 = 30 sec.	DN 65 / DN 200 = 30 sec.
> DN 200 = 180 sec.	> DN 200 = 60 sec	> DN 200 = 60 sec

DIN	body test	hydraulic test	pneu test
3230			
PN6	9 bar	7 bar	6 bar
PN10	15 bar	11 bar	6 bar
PN16	24 bar	17,6 bar	6 bar
PN25	38 bar	27,5 bar	6 bar

API598	body test	hydraulic test
ANSI125	21 bar	18 bar
ANSI150	30 bar	22 bar
ANSI300	78 bar	58 bar

Flanges to be used

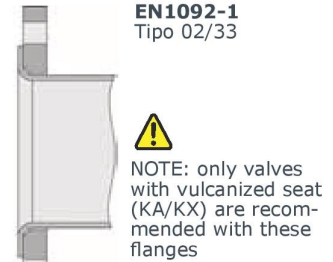
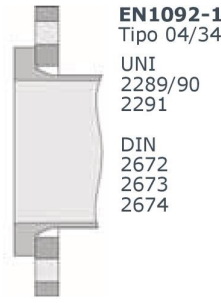
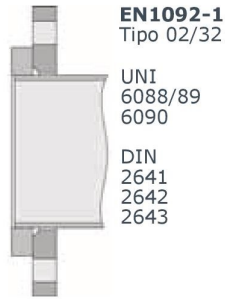
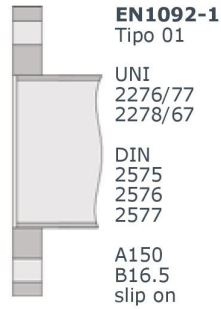
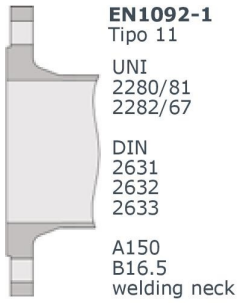

Bolts and rods dimensions

DN	Wafer valves								
	PN 10			PN 16			ANSI 150		
	Bolts	Rods	N°	Bolts	Rods	N°	Bolts	Rods	N°
40	M16x90	M16x100	4	M16x90	M16x100	4	M14x90	M14x110	4
50	M16x100	M16x120	4	M16x100	M16x120	4	M16x100	M16x130	4
65	M16x110	M16x130	8	M16x110	M16x130	8	M16x110	M16x140	4
80	M16x110	M16x130	8	M16x110	M16x130	8	M16x120	M16x150	4
100	M16x120	M16x140	8	M16x120	M16x140	8	M16x120	M16x150	8
125	M16x120	M16x150	8	M16x120	M16x150	8	M20x130	M20x160	8
150	M20x130	M20x160	8	M20x130	M20x160	8	M20x140	M20x160	8
200	M20x140	M20x170	8	M20x140	M20x170	12	M20x150	M20x170	8
250	M20x150	M20x180	12	M24x150	M24x180	12	M22x160	M22x190	12
300	M20x160	M20x190	12	M24x160	M24x190	12	M22x170	M22x210	12
350	M20x160	M20x190	16	M24x170	M24x200	16	M24x180	M24x220	12
400	M24x190	M24x220	16	M27x210	M27x240	16	M27x210	M27x250	16
450	M24x200	M24x230	20	M27x220	M27x250	20	M27x230	M27x270	16
500	M24x210	M24x240	20	M30x240	M30x280	20	M27x250	M27x290	20

DN	Lug valves - Double Flange valves					
	PN 10		PN 16		ANSI 150	
	Bolts	N°	Bolts	N°	Bolts	N°
40	M16x30	8	M16x30	8	M14x30	8
50	M16x35	8	M16x35	8	M16x35	8
65	M16x40	16	M16x40	16	M16x40	8
80	M16x40	16	M16x40	16	M16x40	8
100	M16x40	16	M16x40	16	M16x45	16
125	M16x45	16	M16x45	16	M20x50	16
150	M20x45	16	M20x45	16	M20x50	16
200	M20x50	16	M20x50	24	M20x55	16
250	M20x55	24	M24x55	24	M22x60	24
300	M20x60	24	M24x60	24	M22x60	24
350	M20x60	32	M24x65	32	M24x65	24
400	M24x70	32	M27x70	32	M27x80	32
450	M24x80	40	M27x80	40	M27x80	32
500	M24x80	40	M30x80	40	M27x90	40

NOTE 1: Screw and rod dimensions have been calculated with WELDING NECK flanges PN 6/10/16 (EN1092-1 Tipe 11) ANSI150 (ANSI B16.5)

NOTE 2: Number of nuts should be double when WAFER valves are assembled with threaded rods.

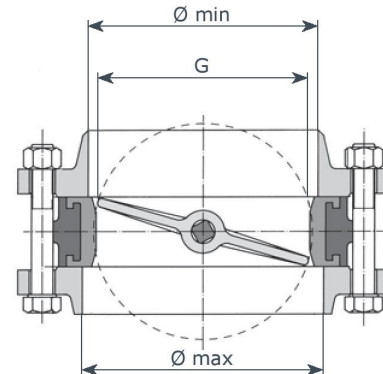

DN	40	50	65	80	100	125	150	200	250	DN	300	350	400	450	500	600	700	800
G	36	35	50	67	87	113	140	191	241	5°	289	332	376	430	479	575	670	757
Ø min	29	44	60	75	98	122	148	196	244	10°	296	332	378	428	478	566	681	782
Ø max	49	62	80	93	118	146	175	225	275	15°	330	372	422	450	500	600	717	815

Handlevers

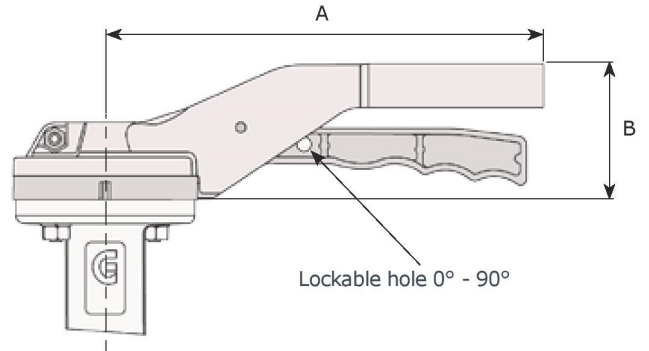

DN	A	B	D	Kg
40 - 100	220	67	93	0.6
125 - 150	275	67	93	0.65
200 - 300	340	76	125	1

Note:
DN 250 - 300 handlever not recommended

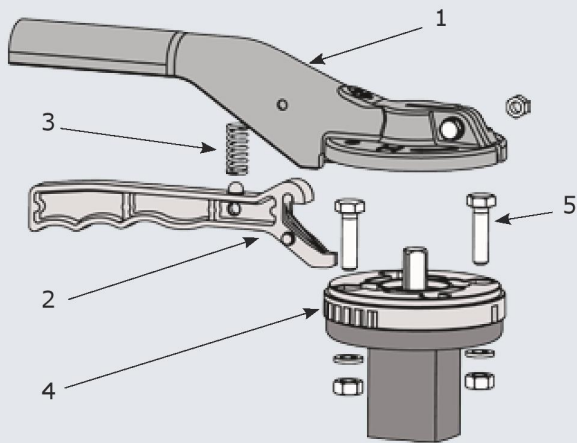
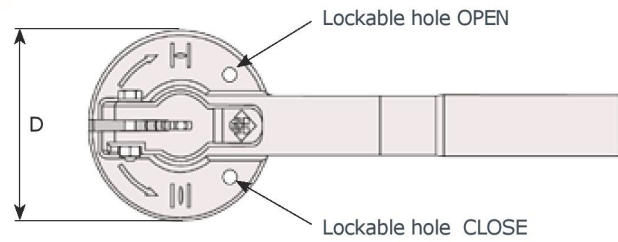

1	lever	aluminium
2	trigger	aluminium
3	spring	stainless steel
4	positioning disc	aluminium
5	screws	steel

* others material on request

OPTIONALS

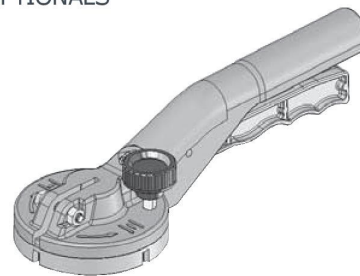

Adjustable handlever

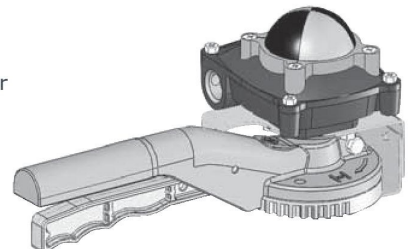

handlever with switch box
(only DN 40/150)

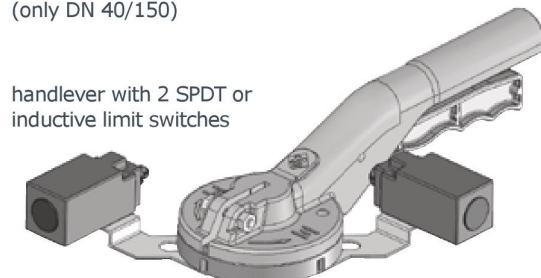

handlever with 2 SPDT or
inductive limit switches

positioning disc DN 40 - 150 designed for flanges ISO 5211 F05/F07



10 positions



2 positions
Open - Closed

positioning disc with two types of regulation: 10 positions or Open/Close

Gearboxes

HW series

body: aluminium
 worm gears: steel
 sector gear: ductile iron
 shaft: stainless steel
 handwheel: steel
 protection: IP65
 T: -20 / +120 °C

low/high temperature execution on request

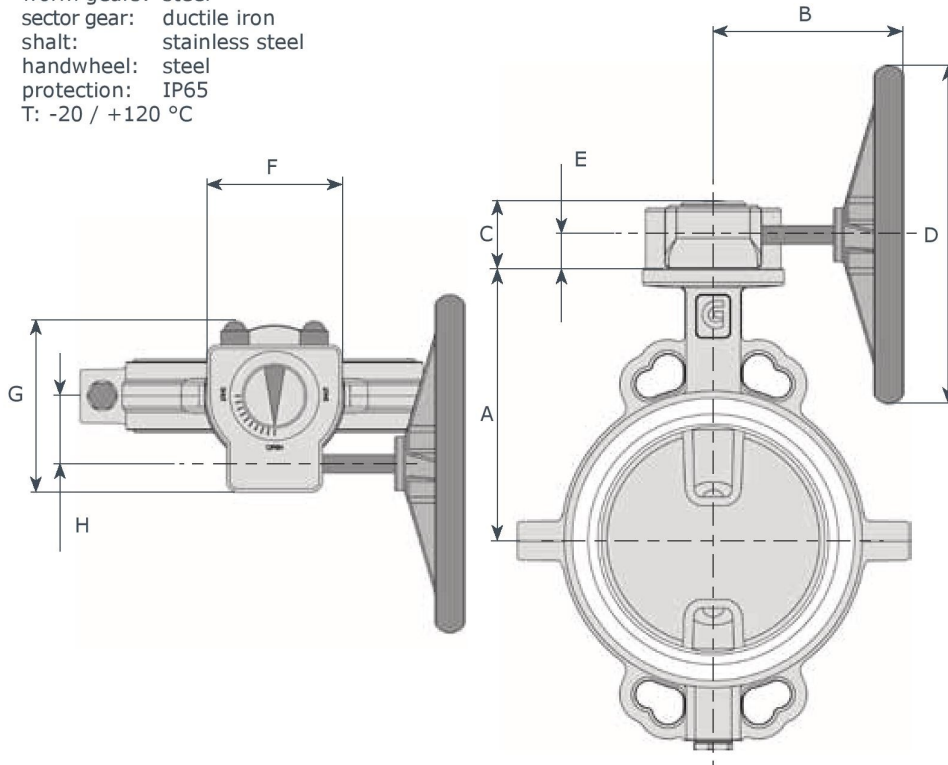

Waterproof valve shaft extension

When necessary, it's possible to extend the valve shaft as indicated in the figure. Construction is in carbon steel with protective paint (on request stainless steel). Max length to be supplied is 6 meters from the flange plane to the valve.

"L" measure should be indicated when ordering.

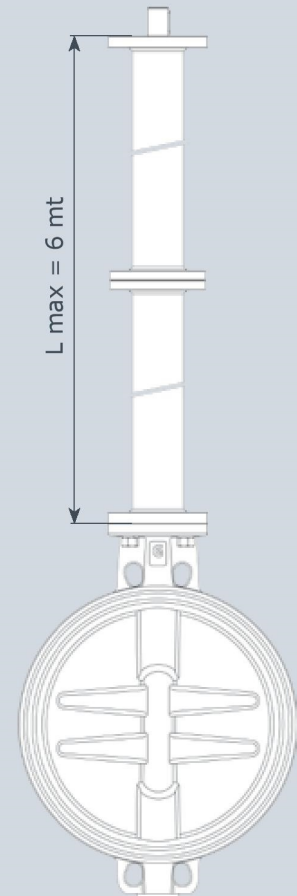

Our technical department is available to solve special applications.

Dimensions

Mod.	B	C	D	E	F	G	H	Kg
HW 070	160	48	140	27	80	115	42	1.6
HW 102	215	56	250	33	120	150	60	3
HW 140	325	95	400	51	185	225	80	10
HW 165	395	105	600	61	230	268	105	20

Coupling valve - actuators

DN	"	TT 10 bar	A	DN	"	TT 10 bar	A
50	2	HW070	138	200	8	HW102	240
65	2 ^{1/2}	HW070	144	250	10	HW102	270
80	3	HW070	158	300	12	HW102	300
100	4	HW070	173	350	14	HW140	330
125	5	HW070	186	400	16	HW140	355
150	6	HW070	202	500	20	HW140B	422