

GATE VALVE

Задвижка

PN 160

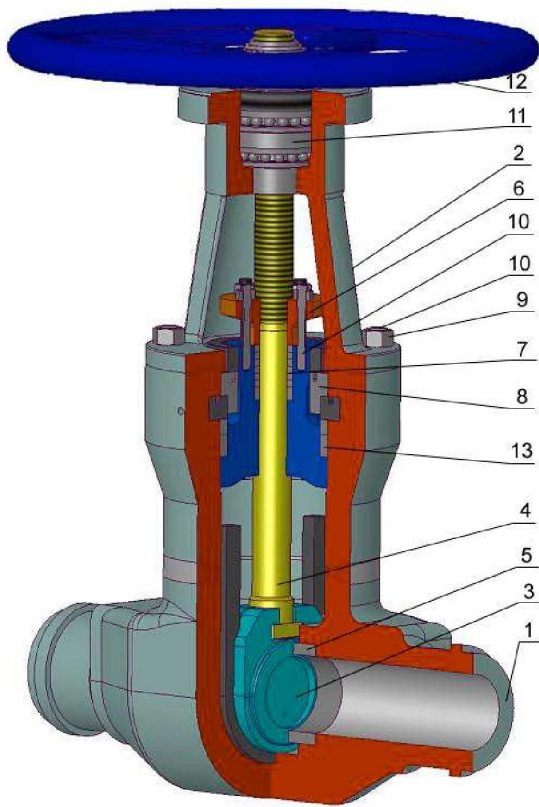

TYPE	S 42
Nominal pressure/ номинальное давление	PN 160
Nominal size/ номинальный размер	DN 65-300

Design / конструкция	EN 1984
Flanges / фланцы	EN 1092-1
Welding end / концы под приварку	EN 12627
Face-to-face/ стр.длина	EN 558-1
Testing/ испытания	EN 12266-1
Pressure/Temperature Давление / температура	EN 12516-1

Operation / управление	
1	Handwheel/ маховик
2	Gearbox / редуктор
3	Electric actuator /электропривод

Pos.	Name / Название	Trim		
		1	5	8
3	Wedge facing /уплотн.поверх.клина	13 Cr	Stellite 6	13 Cr
5	Seat facing /уплотн.поверх.седла	13Cr	Stellite 6	Stellite 6

Pos	Part / деталь	Material / материал			
		-29 - +400 °C	-20 - +593 °C	-47 - +340 °C	-70 - +350 °C
		EN - DIN (ASTM)	EN - DIN (ASTM)	EN - DIN (ASTM)	EN - DIN (ASTM)
1	Body / корпус	GS-C25 (WCB)	GS-17CrMo5-5 (WC6)	GS-20Mn5 (LCB)	GX5CrNi 18-9 (CF8)
2	Yoke / хомут	GS-C25 (WCB)	GS-17CrMo5-5 (WC6)	GS-20Mn5 (LCB)	GX5CrNi 18-9 (CF8)
3	Wedge / клин	C 22 (A105)+ weld-on	24CrMoV (F11)+weld-on	X15Cr13 (F6)+weld-on	X5CrNi 18.10 (F304)+weld
4	Stem / пиндель	X15Cr13 (A182 F6)	24CrMoV 5 5 (A182 F11)	X15Cr13 (A182 F6)	X5CrNi 18.10 (F304)
5	Seat / седло	C 22 (A105)+ weld-on	24CrMoV (F11)+weld-on	X15Cr13 (F6)+weld-on	X5CrNi 18.10 (F304)+weld
6	Packing flange / фланец сальника	GS-C25 (WCB)	GS-17CrMo5-5 (WC6)	GS-20Mn5 (LCB)	GX5CrNi 18-9 (CF8)
7	Packing / сальник	GRAPHITE	GRAPHITE	GRAPHITE	GRAPHITE
8	Ring / Кольцо уплотнительное	St 37-2 (A105)	24CrMoV 5 5 (A182 F11)	TstE 355 (LF2)	X5CrNi 18.10 (F304)
9	Nut / гайка	C 45 (A194 2H)	C 45 (A194 2H)	24 CrMo5 (A194 4)	C 45 (A194 2H)
10	Bolt / болт	42 CrMo4 (A193 B7)	42 CrMo4 (A193 B7)	24 CrMo5 (A182 L7)	42 CrMo4 (A193 B7)
11	Stem nut / гайка шпинделя	ZQAI9-4 (ZQAI9-4)	ZQAI9-4 (ZQAI9-4)	ZQAI9-4 (ZQAI9-4)	ZQAI9-4 (ZQAI9-4)
12	Hand Wheel / маховик	GGG-40 (A47)	A47 (A47)	GGG-40 (A47)	GGG-40 (A47)
13	Sealing / уплотнение	GRAPHITE	GRAPHITE	GRAPHITE	GRAPHITE

All gate valves obtain pressure sealed cover /

Other material specification upon request / другое исполнение по заказу

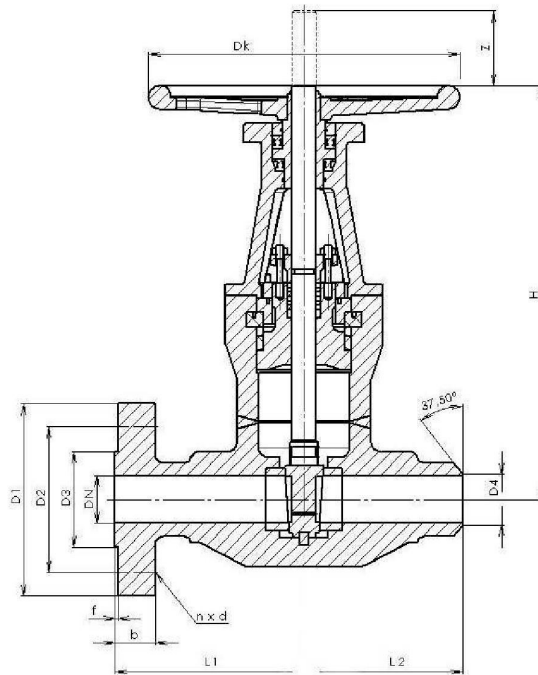

Main and connecting dimensions / главные и присоед. Размеры								
DN	65	80	100	125	150	200	250	300
D1	220	230	265	315	355	430	515	585
D2	170	180	210	250	290	360	430	500
D3	122	138	162	188	218	285	345	410
D4	According to pipe dimensions / согласно размеру трубы							
b	42	45	50	56	62	75	88	100
f	3	3	3	3	3	3	3	4
n	8	8	8	8	12	12	12	16
d	26	26	30	33	33	36	39	42
Bolt / болт	M24	M24	M27	M30	M30	M33	M36	M39
z	85	92	117	150	170	225	275	330
Dk	400	400	400	500	500	630	710	800
H	475	610	610	780	780	940	1140	1140
L1 (RF)	360	390	450	525	600	750	900	1050
L2 (BW)	360	450	450	500	550	650	800	900
m (kg) RF/BW	70/47	112/95	129/96	216/194	235/212	515/385	1000/767	1650/1180

